



Modulators

Digital Intensity Modulators

2.5Gb/secPage ②

2.5Gb/sec Small Form FactorPage ③

2.5Gb/sec with AttenuatorPage ④

10-12.5Gb/sec Integrated Modulator and Driver ModulePage ⑤



Analogue Intensity Modulators

CATV Dual Optic ModulatorPage ⑥

10 / 20 / 40GHz ModulatorPage ⑦





2.5 Gb/s Integrated Optic Intensity Modulator

SD-2.5

- Chirp Free Operation
- Titanium Indiffused Waveguides
- Full C and L Band Operation
- Low Insertion Loss
- > 10 dBm Output Power
- High Extinction Ratio
- Integrated Photodiode Optional

Applications

- Zero Chirp External Intensity Modulation
- Ideal for 25 GHz and 50 GHz Channel Separation
- Low cost Long-Haul Networks (> 1000 km reach)
- Wavelength Tunable Tx Units

Avanex Integrated Optic Intensity Modulators are based on a Waveguide Mach Zehnder Interferometer structure. Titanium indiffusion in x-cut, y-propagating Lithium Niobate substrates provides highly reliable and thermally stable devices with very low insertion loss. Avanex 2.5 Gb/s digital modulators are designed for applications in advanced communication networks where chirp free signal generation at medium bit rates is required. More than a decade of experience in development and volume production of LiNbO₃ components guarantee superior reliability and performance of Avanex's modulator product line. Suitable driver amplifiers are available through Avanex recommended partners.

Absolute Maximum Ratings

Parameter	Conditions	Min	Max
Max Input Power (Electrical)	dBm	-	25
Max Input Power (Optical)	mW CW	-	100
Maximum Operating Temperature Variation Rate	°C/min	-	1
Storage Temperature Range	°C	-40	+85
Operating Temperature Range	°C	0	+70

Specifications

Parameter		
Optical		
Operating Wavelengths Range		C and L Band
Insertion Loss	dB	≤ 4.5
Extinction Ratio (DC)	dB	≥ 20
Return Loss, Without Connectors	dB	≤ -50
Electrical		
S 21 Electro Optic Bandwidth (-3 dB)	GHz	≥ 3
S 11 Electrical Return Loss	dB	≤ -10
RF V • Voltage (@ 1 kHz)	V	≤ 5.5
Bias V • Voltage (@ 1 kHz)	V	≤ 8.0
PRBS Electrical Drive Voltage (V amp)	V	≤ 4.5
Dynamic Extinction Ratio	dB	≥ 15
Input Connector Impedance	Ω	50

Where not specified, parameters are measured at 25°C

Pin-Out and Fibres Specifications

RF Connector	SMA
Bias Connector	SMA
Input Fibre	Avanex/Fujikura SM15P UV/UV400 (Panda fibre)
Output Fibre Avanex	SMF28 ⁽¹⁾

⁽¹⁾ Other output fibres available on request

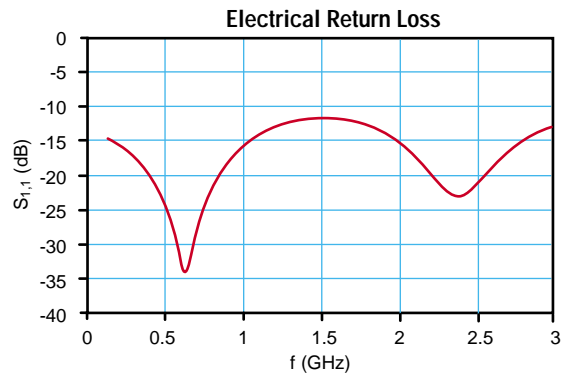
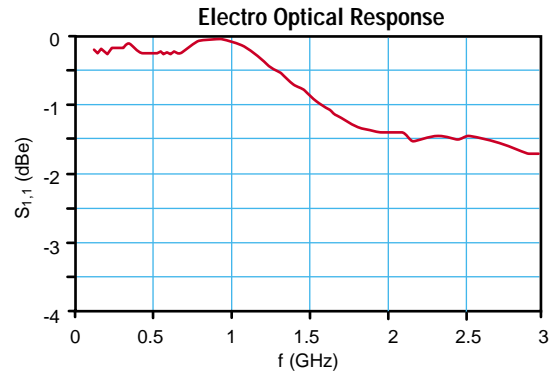

Eye Diagram

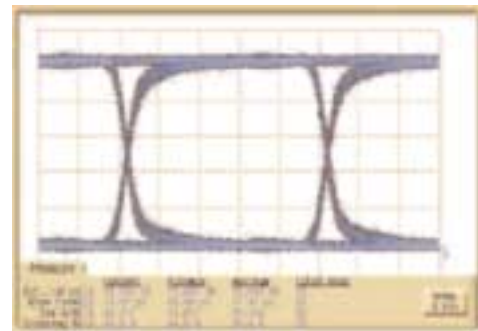

Package Footprint

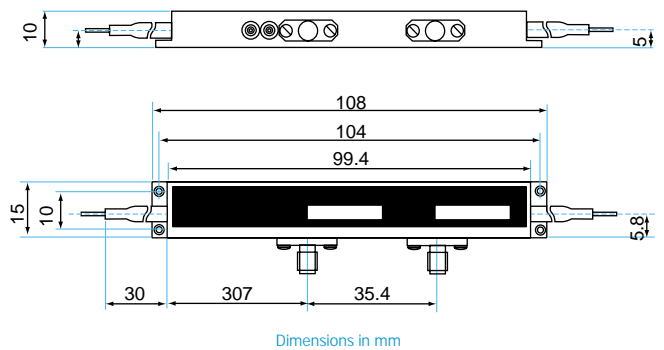

Ordering Information

SD2.5-O-03P-Px-yyzz-00

x	Output Fibre	P = Polarisation Maintaining Fibre S = Standard Single Mode Fibre
yy, zz	Input and Output Connectors	NC = No Connectors FP = FC/SPC Connectors

Other connectors available on request



2.5 Gb/s Integrated Optic Intensity Modulator Small Form Factor

IM-2.5

- **Minimised Form Factor, 6.5 cm Boot-to-Boot**
- **Reduced Cost**
- **EML-Driver Compatible (<3V)**
- **Covers Extended C and L Band**
- **Enables >10 dBm Output Power**
- **Fully Footprint Compatible to other "Mini" Modulators**
- **Further Enhanced Bias Stability**
- **Integrated Photodiode Optional**

Applications

- **High Performance, Chirp Free Signal Generation**
- **Long-Haul Transmission with > 1000 km Reach**
- **Ideal for 25 GHz and 50 GHz Channel Separation**
- **Low Cost DWDM Metro Core**
- **Low Cost Long-Haul Networks**
- **Wavelength Tuneable Tx Units**

Avanex has designed this advanced 2.5 Gb/s modulator specifically for application in emerging DWDM Metro Systems where cost, size and performance are key factors. Enabling maximum bandwidth efficiency, this modulator replaces EMLs in systems designed for channel spacings of 50 and 25 GHz. The potential for >10 dB higher output power can contribute to reduce amplifier stages in Metro networks. Moreover, Lithium Niobate opens the "L" band for DWDM Metro Systems. The potential channel count can be increased by a factor of ten compared to EMLs. Avanex's new 2.5 Gb/s Small Form Factor Lithium Niobate Modulator offers a very cost-effective solution for high performance extended Metro and Long-Haul DWDM networks at medium bit-rates. Suitable driver amplifiers are available through Avanex recommended partners.

Absolute Maximum Ratings

Parameter	Conditions	Min	Max
Max Input Power (Electrical)	dBm	-	25
Max Input Power (Optical)	mW	CW	100
Maximum Operating Temperature Variation Rate	°C/min	-	1
Storage Temperature Range	°C	-40	+85
Operating Temperature Range	°C	0	+70

Specifications

Parameter		
Optical		
Operating Wavelengths Range		C and L Band
Insertion Loss	dB	≤ 4.0
Extinction Ratio (DC)	dB	≥ 20
Return Loss, Without Connectors	dB	≤ -50
Electrical		
S 21 Electro Optic Bandwidth (-3 dB)	GHz	≥ 3.0
S 11 Electrical Return Loss	dB	≤ -10
RF V_{π} Voltage (@ 1 kHz)	V	≤ 4.5
Bias V_{π} Voltage (@ 1 kHz)	V	≤ 4.0
PRBS Electrical Drive Voltage (V_{amp} @ ER_{max})	V	≤ 3.8
Max. Dynamic Extinction Ratio	dB	≥ 15
Dynamic Extinction Ratio ($V_{amp} = 3V$)	dB	≥ 13
Input Connector Impedance	Ω	50

Where not specified, parameters are measured at 25°C

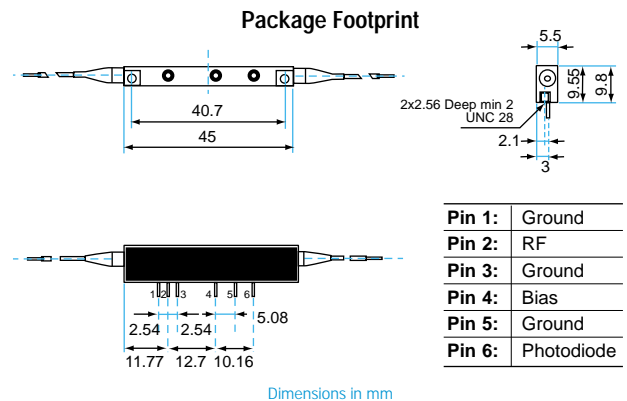
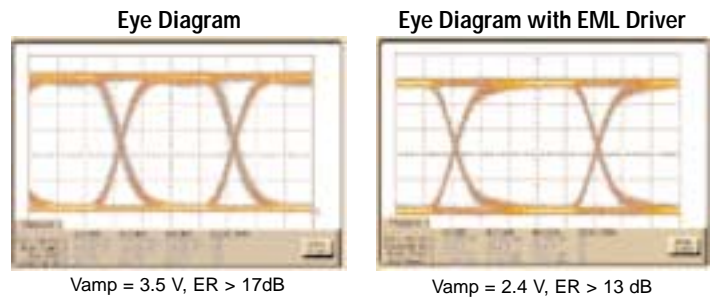
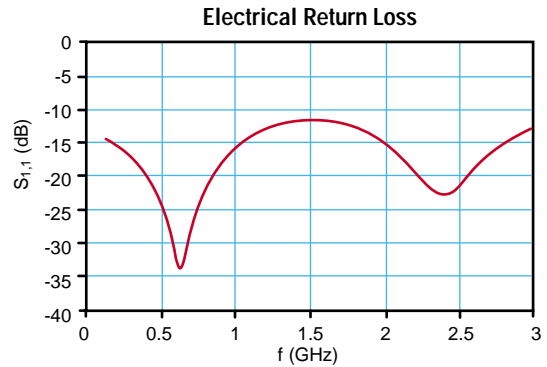
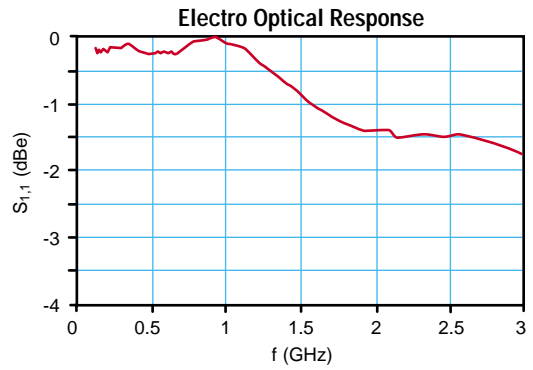

Ordering Information

IM2.5-O-03P-Px-yyzz-00

x	Output Fibre	P = Polarisation Maintaining Fibre S = Standard Single Mode Fibre
yy, zz	Input and Output Connectors	NC = No Connectors FP = FC/SPC Connectors

Other connectors available on request

Pin-Out and Fibres Specifications

RF Connector	LEAD Pins
Bias Connector	LEAD Pins
Input Fibre	Avanex/Fujikura SM15P UV/UV400 (Panda fibre)
Output Fibre	Avanex SMF28 ⁽¹⁾

(1) Other output fibres available on request



2.5 Gb/s Integrated Optic Intensity Modulator with Attenuator

SD -2.5 -A:

- Chirp Free Operation
- Titanium Diffused Waveguides
- Full C and L Band Operation
- Low Insertion Loss
- >10 dBm Optical Output Power
- Very High Extinction Ratio
- Non Periodic, Monotonic Attenuation Characteristic
- Integrated Photodiode Optional

Applications

- Zero Chirp External Intensity Modulation with Power Pre-Emphasis
- Long-Haul Transmission with >1000 km Uncompensated Reach
- <50 GHz Channel Separation DWDM
- Dynamic Optical Power Control
- Low Cost DWDM Networks
- Wavelength Tunable Tx Units

Avanex's 2.5 Gb/s Digital Intensity Modulator with Integrated Variable Attenuator enables pre-emphasis of each channel in long and ultra-long haul DWDM systems. As with all Avanex Mach-Zehnder modulators, the Titanium indiffusion process in x-cut, y-propagating Lithium Niobate substrates guarantees highest reliability and very low temperature drifts. Intensity Modulators with integrated variable optical attenuators enable high flexibility in DWDM system operation. Suitable driver amplifiers are available through Avanex recommended partners.

Absolute Maximum Ratings

Parameter	Conditions	Min	Max
Max Input Power (Electrical)	dBm	-	25
Max Input Power (Optical)	mW	-	100
Max ΔV Bias Attenuator	V CW	-	40
Max V Bias Electrode	V Unbalanced	-	30
Maximum Operating Temperature Variation Rate	$^{\circ}\text{C}/\text{min}$	-	1
Storage Temperature	$^{\circ}\text{C}$	-40	+85
Operating Temperature Range	$^{\circ}\text{C}$	0	+70

Specifications

Optical		
Operating Wavelengths Range		C and L Band
Insertion Loss	dB	≤ 5.2
Extinction Ratio (DC)	dB	≥ 20
Return Loss, Without Connectors	dB	≤ -50
Attenuation Range ($\pm 20\text{V}$)	dB	≥ 10
Electrical		
S 21 Electro Optic Bandwidth (-3 dB)	GHz	≥ 2.5
S 11 Electrical Return Loss	dB	≤ -10
RF V • Voltage (@ 1 kHz)	V	≤ 5.0
Bias V • Voltage (@ 1 kHz)	V	≤ 5.0
PRBS Electrical Drive Voltage (V amp)	V	≤ 4.5
Dynamic Extinction Ratio	dB	≥ 15
Input Connector Impedance	Ω	50

Where not specified, parameters are measured at 25 $^{\circ}\text{C}$

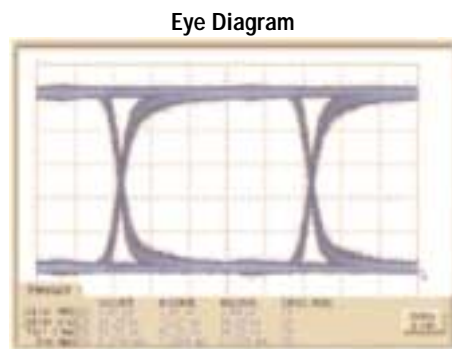
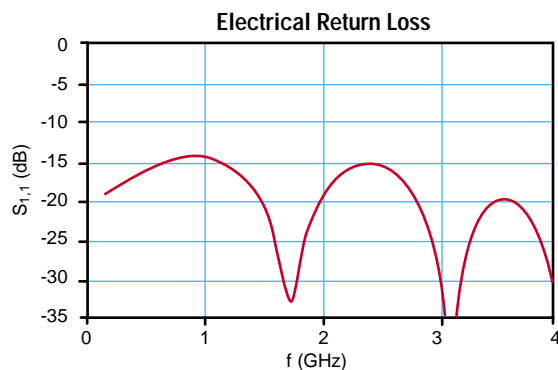
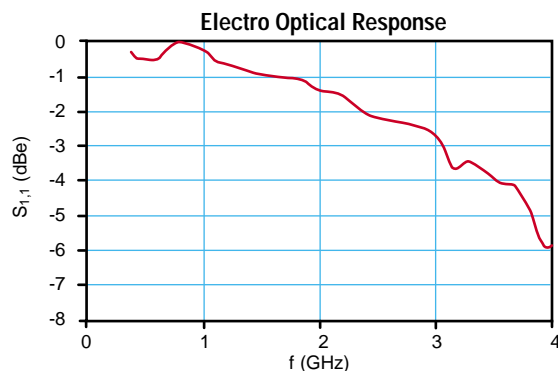

Package Footprint

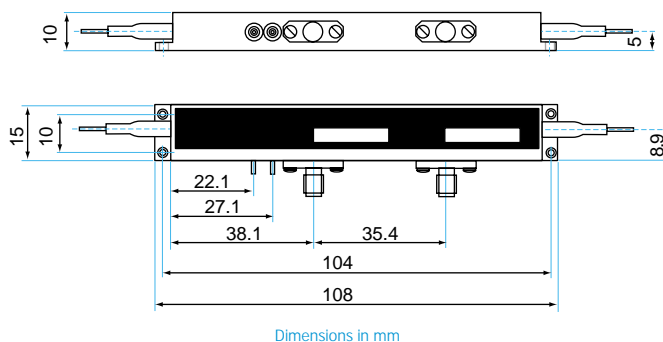

Dimensions in mm

Ordering Information

SD2.5-A-03S-Px-yyzz-00

x	Output Fibre	P = Polarisation Maintaining Fibre S = Standard Single Mode Fibre
yy, zz	Input and Output Connectors	NC = No Connectors FP = FC/SPC Connectors

Other connectors available on request

Pin-Out and Fibres Specifications

RF Connector	SMA
Bias Connector	SMA
Attenuation Connector	Lead Pins
Input Fibre	Avanex/Fujikura SM15P UV/UV400 (Panda Fibre)
Output Fibre	Avanex SMF28 ⁽¹⁾

⁽¹⁾ Other output fibres available on request



10-12.5 Gb/s Integrated Modulator and Driver Module

IM-DM5

- Fully Matched Elements for High Performance Modulation
 - Lithium Niobate Modulator
 - RF Drive Electronics
 - Monitor Photodiode
 - Bias Control Circuit
- Chirp Free
- Operates Across Full C and L Band
- Low Power Consumption
- Hermetically Sealed Package
- Small Form Factor
- Temperature Compensated

Applications

- SONET/SDH and DWDM Systems
- FEC Capable
- Efficient Transponder / Transceiver Architecture

Avanex's Integrated Modulator and Driver Module (IMDM) combines key elements required to implement a high performance LiNbO₃ based transponder. The module integrates a Lithium Niobate MZ modulator together with RF driver, monitor photodiode and Bias control circuitry. This solution simplifies the fibre management inside a transponder card by providing a ready to assembly unit. Designers can also save valuable board space and significantly reduce development and manufacturing time.

Ordering Information

DM5-O-13P-Px-yyzz-oo

x	Output Fibre	P = Polarisation Maintaining Fibre S = Standard Single Mode Fibre
yy, zz	Input and Output Connectors	NC = No Connectors FP = FC/SPC Connectors

Other connectors available on request

Absolute Maximum Ratings

Parameter	Conditions	Min	Max
Max Input Power (Electrical)	mW CW		100
Maximum Operating Temperature Variation Rate		1	°C/min
DC Power Supply Positive	V I = 275 mA	8.5	9.45
DC Power Supply Negative	V I = 50 mA	-9.45	-8.5
Storage Temperature	°C	-40	+85
Operating Temperature Range	°C	0	+70

Package Footprint

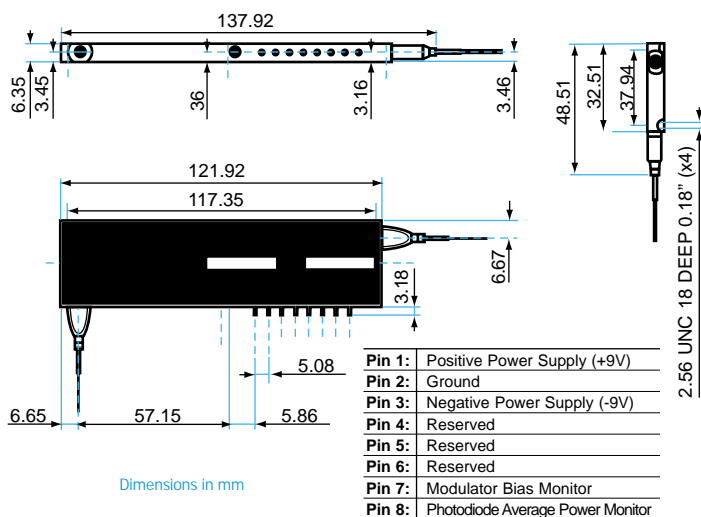

Eye Diagrams

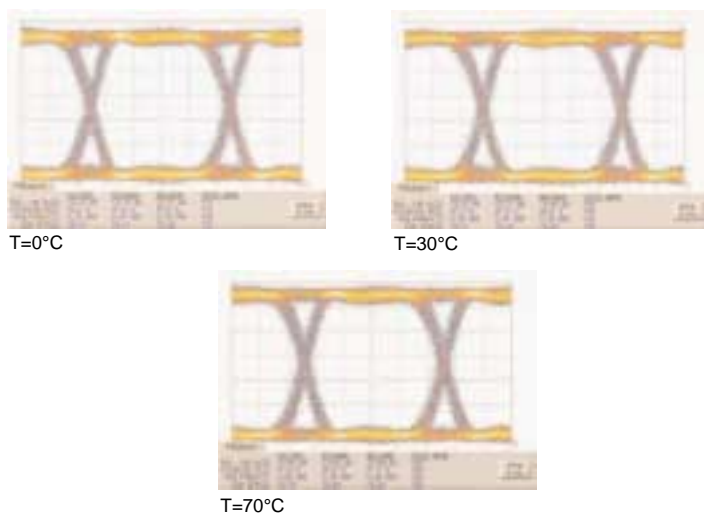

Specifications

Parameter	Unit	
Optical		
Polarity	-	Non Inverting and Inverting
Operating Wavelengths	-	C and L Band
Optical Insertion Loss	dB	≤5
Optical Extinction Ratio (10.7 Gb/s PRBS; 2 ³¹ -1)	dB	≥13.0
Optical Return Loss	dB	≤-50
Crossing Point Variation	%	± 3
RF Input		
Electrical Return Loss	dB	≤-12
Rise Time	ps	29
Jitter p-p (total, including pattern dependency)	ps	10
Input Drive Voltage	V	0.4
Electrical Supply		
Power Dissipation	W	≤3
PD Monitoring		
Responsivity	V/mW	0.25
Vbias Monitoring		
V _{pin} /V _{bias} Modulator	-	0.5

Where not specified, parameters are measured at 25°C

Pin-Out and Fibres Specifications

RF Connector	Flush GPO
Power and Monitor Connector	LEAD Pins
Input Fibre	Avanex/Fujikura SM15P UV/UV250 (Panda fibre)
Output Fibre	Avanex SMF28 ⁽¹⁾

⁽¹⁾ Other output fibres available on request

Dual Optic Analogue Modulator

AM-1:

- *Ti-Diffused Waveguides*
- *1550 nm Window*
- *Travelling Wave Electrode Design*
- *Separate Bias Electrode*
- *Dual Output Port, 180° Phase Difference*
- *Low CSO on Both Outputs*
- *Low Drive Voltage*
- *Low Insertion Loss*
- *High Efficiency Phase Modulator Electrode*

Applications

- *External Intensity Modulation in Analogue Transmission Systems for Cable TV*

Avanex Analogue Intensity Modulator is based on a Mach-Zehnder waveguide interferometer and is manufactured using the Titanium indiffusion in x-cut, y-propagating Lithium Niobate substrates. The modulator can be actively controlled by electronics to provide high level of CSO and CTB suppression, as needed for CATV application.

Absolute Maximum Ratings

Parameter	Conditions	Min	Max
Max RF Input Power	dBm	-	25
Max Phase Input Power	dBm	-	35
Max Optical Input Power	mW	CW	100
Maximum Operating Temperature Variation Rate	°C/min	-	1
Storage Temperature Range	°C	-20	+85
Operating Temperature Range	°C	0	+70

Specifications

Parameter		
Optical		
Operating Wavelength Range	nm	1540 – 1560
Insertion Loss	dB	≤ 4
Insertion Loss Imbalance	dB	≤ 0.5
Extinction Ratio	dB	≥ 20
Return Loss	dB	≥ -55
Electrical		
E/O Bandwidth Roll-Off (from 50 MHz to 200 MHz)	dB	≤ 0.8
E/O Bandwidth Roll-Off (from 200 MHz - 1 GHz)	dB	≤ 2
RF Power	dBm	≥ 12.7
Bias V • Voltage (@ 1 kHz)	V	8.5
Phase V • Voltage (@ 1 kHz)	V	≤ 6.0
Return Loss (electrical)	dB	-10
RF Connector Impedance	Ω	25
Bias Connector Impedance	Ω	≥ 1000
Phase Connector Impedance	Ω	50
Modulated Phase Difference Between Outputs	°	± 0.5
Max CSO	dBC	-70

Where not specified, parameters are measured at 25 °C

Pin-Out and Fibres Specifications

RF Connector	SMA
Bias Connector	SMA
Phase Connector	SMA
Input Fibre	Avanex/Fujikura SM15P UV/UV400 (Panda fibre)
Output Fibre	Avanex SMF28 ⁽¹⁾

(1) Other output fibres available on request

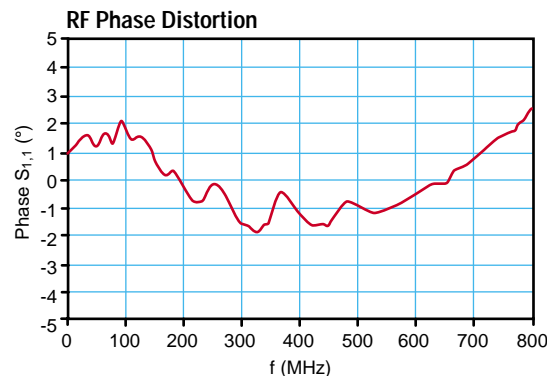
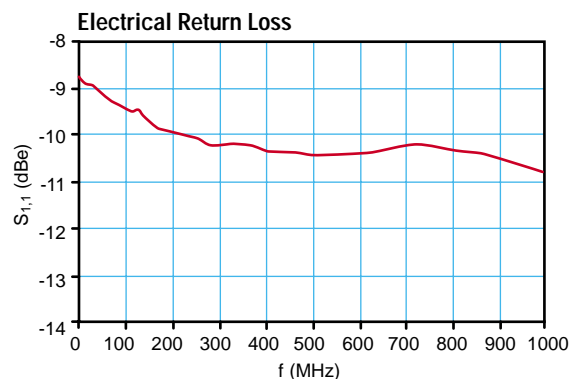
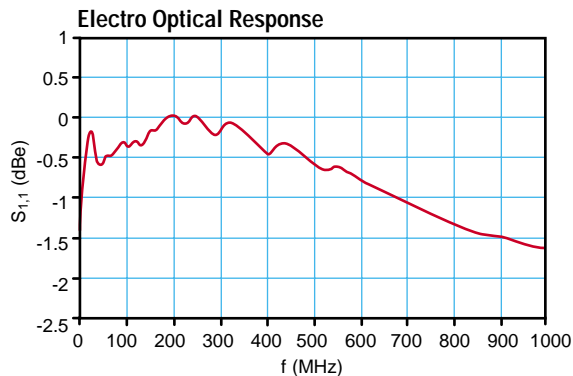

Package Footprint

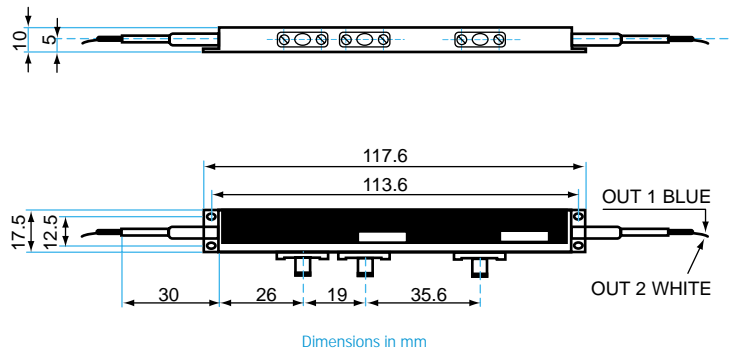

Ordering Information

AM01-O-01P-Px-yyzz-00

x	Output Fibre	P = Polarisation Maintaining Fibre S = Standard Single Mode Fibre
yy, zz	Input and Output Connectors	NC = No Connectors FP = FC/SPC Connectors

Other connectors available on request.

10/20/40 GHz Analogue Modulator

AM - 10/20/40

- Titanium In-Diffused Waveguides
- X-cut LiNbO₃
- Low Drive Voltage Compatible
with Commercially Available Drivers
- Low Optical Insertion Loss
- 1300 nm and 1550 nm Wavelength Range
- Operating up to 40 GHz
- Integrated Photodiode Available on Request
- Small Footprint

Applications

- Antenna Remoting
- High Frequency Fibre Optic Links
- Analog Microwave over Fibre
- Delay Lines Telemetry Systems

These high performance integrated optical modulators have been specifically designed to target an emerging market in the field of civil and military transmission. Avanex analogue modulators combine high linearity with low driving voltage and small footprint, covering all the frequency range from 10 to 40 GHz and both the 1300 nm and 1550 nm wavelength window. The increasing demand to shift the transmission frequency in microwave fibre optic links towards higher frequency find in Avanex analog modulators the most advanced and suitable answer. The experience and know-how of Avanex engineers is available to satisfy the most challenging requests and to customise our products to customer's requests.

Absolute Maximum Ratings

Parameter	Conditions	Min	Max
Max Input Power (Electrical)	dBm RF port	-	25
Max Input Power (Optical)	mW	-	100
Maximum Operating Temperature Variation Rate	°C/min CW	-	1
Storage Temperature Range	°C	-40	+85
Operating Temperature Range	°C	0	+70

Specifications

Parameter	Conditions	Min	Max
Optical			
Operating Wavelength Range	nm	1280 – 1340	1525 – 1615
Insertion Loss	dB	< 4.5	< 5
Return Loss	dB	> 50	> 50
Extinction Ratio	dB	> 20	> 20
Electrical			
S 21 Electro Optic Bandwidth (-3 dB)	GHz	>10 >20 >33	>10 >20 >33
S 11 Electrical Return Loss	dB	< -10	< -10
RF V • Voltage (@ 1 kHz)	V	4.5	5
Bias V • Voltage (@ 1 kHz)	V	5.5	5.5
2 nd Harmonic Suppression	dB	45	45
Input Connector Impedance	Ω	50	50
Photodiode Responsivity	A/W	10 ⁻³	10 ⁻³
Linearity		± 10%	± 10%

Pin-Out and Fibre Specifications

RF Connector	GPO for 10 GHz V Connector ⁽¹⁾ for 20 and 40 GHz
Bias Connector	LEAD Pins
Input Fibre	1300 nm: Avanex Puremode PM1300 UV/UV250 1500 nm: Avanex Puremode PM1500 UV/UV250
Output Fibre	1300 nm: Avanex SMF28 1500 nm: Avanex SMF28

(1) V Connector is a registered trademark of Anritsu Corporation

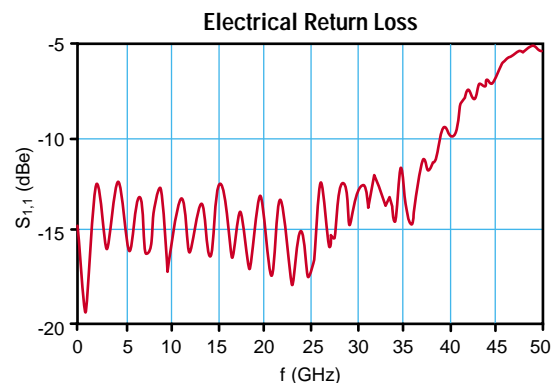
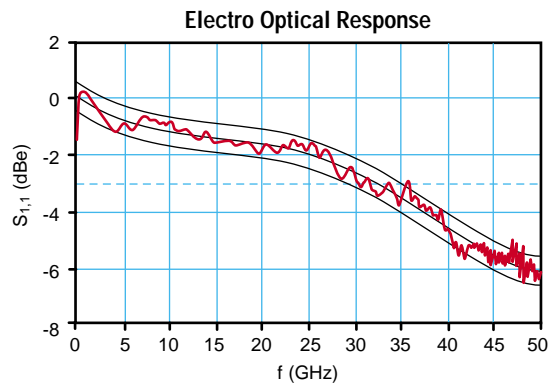

Package Footprint

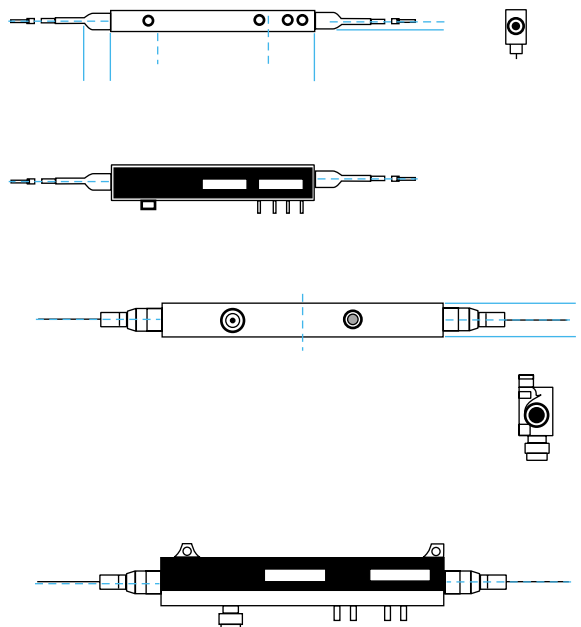

Ordering Information

AMbb-o-bbP-Px-yyzz-00

bb	Bandwidth	10 = 10 GHz 20 = 20 GHz 30 = 30 GHz
x	Output Fibre	P = Polarisation Maintaining Fibre S = Standard Single Mode Fibre
yy, zz	Input and Output Optical Connectors	NC = No Connectors FP = FC/SPC Connectors

Other connectors available on request