



Laser Diode Modules

Laser Diode Modules

Page



Standard Modules 4

- Self Contained CW Systems4
- Analogue Modulated 20MHz Module5
- Separated Geometry Systems5



Advanced Modules 6

- Micro-Optic Circularised Module6
- Bulk Optic Circularised Module6
- Temperature Controlled Module7
- Circularised and Temperature Controlled Module7
- High Power Module7



Blue Laser Modules 8

- Blue, Violet and Ultra-Violet Modules8



Instrument Quality Modules 9

- IQ Series Laser Modules9
- IQ Head9



Pulsers 10

- ML Series Pulse Laser Modules10
- ILC and IPC Series Pulsed Laser Modules and Controllers10



Accessories and Options 11

- Benchtop Power Supplies11
- Modulation, Lens, and Remote Control Options12-13
- Optical Fibre Connectorisation14
- Mounting Brackets14



WHAT IS A SEMICONDUCTOR DIODE?

In its simplest form, the semiconductor laser is a p-n junction of a single crystal of semiconductor material arranged in a Fabry-Perot cavity. The type and configuration of the material used determines the optical characteristics of the laser diode emission. Laser 2000 provides a wide range of Fabry-Perot laser diode wavelengths and powers for many different applications. In addition to the diode lasers detailed here, laser diodes specifically for communications applications, and high power laser diodes and arrays for pumping solid state lasers are detailed in our "Laser Diodes" PDF. Furthermore we also offer custom wafer design and laser diode packaging services.

DRIVING LASER DIODES

Semiconductor laser diodes are highly susceptible to damage from static electricity, mains noise, electrical surges and spikes. Laser 2000 drive electronics are designed to filter out noise and transients and provide a number of additional safety features to protect laser diodes and prevent failures. If you have a laser diode and require a laser diode driver, Laser 2000 will provide the system best suited to your requirements. Refer to "Laser Diode Drivers" PDF.

WAVELENGTH

The centre wavelength of a Fabry-Perot laser diode is given as a nominal value at 25°C and is subject to a tolerance of ±10nm typically. The wavelength varies with temperature by approximately 0.2nm-0.5nm/°C, depending on the diode. Laser diodes do not exhibit continuous

wavelength tuning with temperature, but instead exhibit a behaviour known as mode hopping where the wavelength changes by a discrete value. This can be a disadvantage for some applications. Using a Peltier effect bipolar thermoelectric controller, the laser diode temperature can be stabilised and even used to tune the emission to a specific wavelength. Laser 2000 supplies a complete range of temperature controlled systems. Alternatively, External Cavity diode lasers allow the wavelength of the laser diode to be adjusted over a range of up to 50nm about the centre wavelength, with as much as 25nm of mode hop free tuning. (see the TEC & MLD, in "Turnkey Systems" PDF).

Laser 2000 will select the wavelength to within 1nm of a specified wavelength at no additional charge (subject to availability). These laser diodes typically have a TEM₀₀ spatial mode and are linearly polarised, with a polarisation ratio of 100:1. Distributed feedback (DFB) lasers exhibit superior temperature stability, although they are limited to telecoms wavelengths.

M² BEAM QUALITY

Laser diodes exhibit high divergence and astigmatism. Laser 2000 provides complete laser diode systems with either a simple focusing lens, microlens or with full correction optics to circularise the beam and remove astigmatism. Fibre launched systems are provided as standard packages or options with singlemode, multimode, large-core, or polarisation maintaining fibre output options.

Blue and UV diodes on page 8.

Standard Package (Ø9.0)

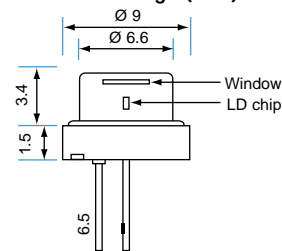

Small Package (Ø5.6)

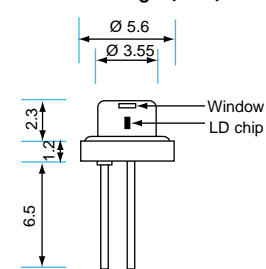

Dimensions in mm



Laser Diodes For Laser Diode Modules

These laser diodes are available, in the majority of cases, from stock.

They are predominantly for use in the Laser 2000 range of laser diode modules, although they are available for purchase without a laser diode module.

Blue & Violet Modules on Page 8

Laser Diode Code #	Typical Centre Wavelength	Maximum Wavelength Tolerance	Output Power (mW)	Operating Temperature (°C)	Package Type (mm dia.)	Typical Iop (mA)	Divergence Degrees FWHM	Spatial Mode	Photodiode Configuration	Source Size (microns)
LD1080	635	630-640	3	50°	5.6	30	8 X 30	S	LDA to PDC	3 X 1
LD1167	635	625-640	5	50°	9	55	8 X 30	S	LDA to PDC	3 X 1
LD1261	635	630-640	15	50°	9	85	8 X 30	S	LDA to PDC	3 X 1
LD1403	639	635-642	35	50°	5.6	102	10 X 31	S	LDA to PDC	3 X 1
LD1242	650	640-660	5	60°	5.6	35	8 X 28	S	LDA to PDC	3 X 1
LD1392	655	640-660	7	50°	5.6	30	8 X 33	S	LDA to PDC	3 X 1
LD1241	658	640-665	35	60°	5.6	90	8.5X22	S	LDC to PDA	3 X 1
LD1328	664	655-667	50	60°	5.6	120	8.5 X 21	S	No PD	3 X 1
LD1084	670	660-680	5	50°	5.6	35	8 X 30	S	LDA to PDC	3 X 1
LD1180	670	660-680	7	60°	5.6	40	6 x 26	S	LDA to PDC	3 X 1
LD1185	670	665-685	10	50°	9	60	8 X 30	S	LDA to PDC	3 X 1
LD1417	685	670-700	60	60°	9	125	9.5 X 20	S	No PD	3 X 1
LD1318	690	680-695	35	70°	5.6	70	8.5 X 19	S	LDC to PDA	3 X 1
LD1420	785	770-800	5	60°	5.6	35	9 X 27	S	LDA to PDC	3 X 1
LD1231	785	775-795	50	60°	9	130	9.5 X 23	S	LDA to PDC	3 X 1
LD1182	785	770-800	60	60°	5.6	165	10 X 25	S	LDC to PDA	3 X 1
LD1348	785	770-800	75	60°	5.6	100	7 X 18	S	LDC to PDA	3 X 1
LD1450	790	785-795	100	40°	9	130	7 X 35	S	LDA to PDC	3 X 1
LD1376	808	803-813	100	40°	9	150	8 X 40	S	LDA to PDC	5 X 1
LD1238	830	820-840	40	60°	9	120	10 X 22	S	LDC to PDA	3 X 1
LD1441	860	850-865	100	40°	9	140	7 X 35	S	LDA to PDC	3 X 1
LD1433	910	905-915	50	50°	9	75	7 X 35	S	LDA to PDC	3 X 1
LD1371	980	975-985	50	60°	9	70	8 X 30	S	LDA to PDC	3 X 1
LD1370	980	975-985	100	60°	9	115	8 X 30	S	LDA to PDC	3 X 1
LD1372	980	975-985	250	60°	9	260	8 X 30	S	LDA to PDC	3 X 1
LD1394	980	975-985	300	50°	9	300	8 X 30	S	LDA to PDC	3 X 1
LD1087	1310	1290-1330	10	85°	5.6	20	25 X 30	S	4 Leads	3 X 1
LD1088	1550	1520-1580	6	85°	5.6	30	25 X 30	S	4 Leads	3 X 1
LD1400	1550	1530-1570	10	50°	9	110	25 X 40	S	LDA to PDC	5 X 1



WHAT IS A LASER DIODE MODULE?

Laser diode modules are simple cost effective laser sources. They incorporate a semiconductor laser diode circuit, collimating lens and laser diode drive circuit, packaged in a rugged housing to provide continuous or pulsed laser output.

LASER DIODES FOR LASER MODULES

All of the laser diodes listed in the table on the left may be incorporated into the range of laser diode modules detailed on the following pages. To confirm that your chosen diode is compatible with your chosen module, please contact Laser 2000.

BEAM POINTING STABILITY

The directionality of the laser diode beam will drift with temperature. The amount of drift is generally less than 1mradian per °C. To respond to those applications requiring higher beam pointing stability, Laser 2000 provides laser diode modules that have been specially designed with a beam pointing stability that is >10 times better than standard systems. For more information, contact Laser 2000.

POWER OUTPUT

The maximum output power emitted by the laser diode is reduced by the module optics. To account for these losses, the maximum diode power should be adjusted by the percentage below.

WAVELENGTH STABILITY & TUNING

If wavelength stability or wavelength tuning is important, systems with built in temperature control may provide simple and effective solutions. (see PPM and APM series, page 7). Alternatively, an external cavity laser provides greater tuning & narrower linewidth (see "Turnkey Systems" PDF).

SAFETY AND PROTECTION

All Laser 2000 modules are designed to prevent damaging electrical spikes, transients and surges from reaching the laser diode. Furthermore, the drive circuit also limits the amount of drive current to the laser ensuring that it always remains within the recommended operating limits.

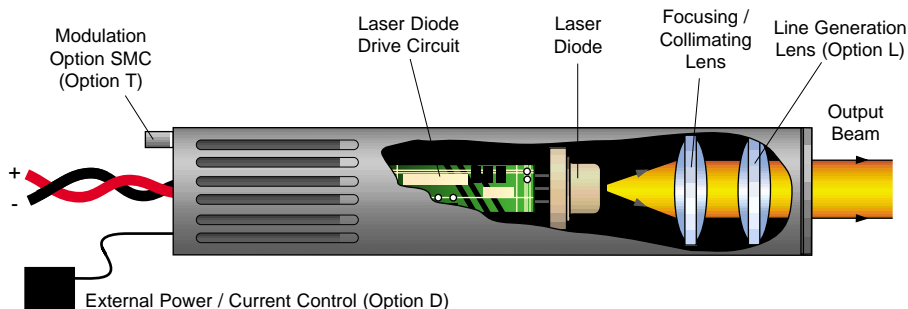

ADJUSTABLE OPTICS

Most of the Laser 2000 laser diode modules are provided with an exchangeable lens system mounted in a 60 tpi adjustable thread. These can be focussed or collimated using the focusing key (where provided). The ACM and APM have a fixed focus. This can be factory set to whatever focus position is required. All laser diode modules typically have a TEM₀₀ spatial mode and are linearly polarised, with a polarisation ratio of >100:1.

An example is given of the typical transmission for a 5mW laser diode. The same rule may be applied to all laser diodes.

Amplitude modulation will reduce the average power output depending on the frequency of modulation and the mark-space ratio.

CONSTANT CURRENT OR CONSTANT POWER?

Most laser diodes operate in closed loop mode, where the power output is monitored and the drive current adjusted automatically to keep the power constant (CP). It may be advisable to operate the device in constant current (CC) to avoid mode hopping in wavelength critical applications, or to prevent damage to the diode at elevated temperatures (thermal runaway). Laser 2000 modules provide both options (depending on module). For advice on when to use CC or CP call Laser 2000.

BEAM QUALITY AND CIRCULARISATION

Laser diodes emit astigmatic elliptical beams. Beam circularisation reduces and may eliminate these two effects depending on the option selected. For more information on beam circularised systems refer to page 6.

Typical power output from a 5mW diode

Module Optics	%	mW
Micro Optics *	80	4.0
Circularisation (APM/ACM)	50	2.5
Standard lens, G3 (All other modules)	75	3.75
Multimode fibre coupled (-F7)	60	3.0
Singlemode fibre coupled (-F2)	25	1.25

* Only available on a limited range of laser diodes (see table below)



Range of Laser Diode Modules

Laser Diodes With Micro-optics (Circularised) For Laser Diode Modules

These laser diodes are available, in the majority of cases from stock.

They are predominantly for use in the Laser 2000 range of laser diode modules, although they are available for purchase without a laser diode module.

Laser Diode Code #	Typ. Centre Wavelength (nm)	Output Power (mW)	Operating Temperature (°C)	Package Type (mm dia)	Typical Iop (mA)	Divergence Degrees FWHM	Spatial Mode	Photodiode Configuration	Source Size (microns)
LD1212	635	5	50°	9	55	8 X 8	S	LDA to PDC	3 X 1
LD1251	635	10	50°	9	80	8 X 8	S	LDA to PDC	3 X 1
LD1338	635	15	50°	9	85	8 X 8	S	LDA to PDC	3 X 1
LD1415	639	35	50°	5.6	102	8 X 8	S	LDA to PDC	3 X 1
LD1350	650	7	60°	5.6	60	8 X 8	S	LDA to PDC	3 X 1
LD1240	658	35	60°	5.6	90	8.5 X 8.5	S	LDC to PDA	3 X 1
LD1360	664	50	60°	5.6	120	8.5 X 8.5	S	No PD	3 X 1
LD1249	670	5	50°	9	55	8 X 8	S	LDA to PDC	3 X 1
LD1248	670	10	50°	9	55	8 X 8	S	LDA to PDC	3 X 1
LD1438	685	60	60°	9	125	8 X 8	S	No PD	3 X 1
LD1340	690	35	70°	5.6	70	8 X 8	S	LDC to PDA	3 X 1
LD1356	785	50	60°	9	130	8 X 8	S	LDA to PDC	3 X 1
LD1362	830	150	50°	9	185	7 X 7	S	LDA to PDC	3 X 1

* Single Unit Cost



These standard laser modules provide high quality optical performance and versatility at a very reasonable cost.

These laser modules are compatible with the laser diodes detailed on page 2. As the final output power is reduced by losses in the optics of the module itself, the laser diode should be selected with a greater output power than that required from the module to compensate for these losses (Refer to the notes on power output on page 3). Laser 2000 will provide a guaranteed minimum (or maximum) output power upon request.

Laser diode modules can be driven from almost any power source provided that it meets the voltage and current requirements of the module in question. Laser 2000 provides power supplies matched to the ideal requirements of these modules (see page 11). They are extremely simple to install and operate. Alternatively, Laser 2000 will provide the device already connected to a suitable power supply and install the unit on site. Contact Laser 2000 for further details.

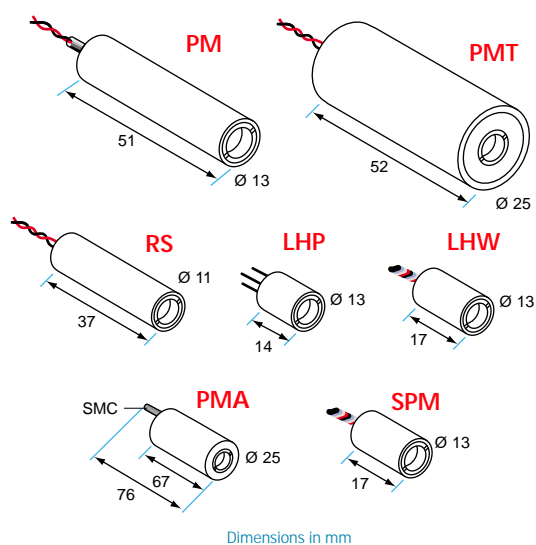

Dimensions in mm

Options

All the laser diode modules on this page may be supplied with a range of additional options. Please refer to pages 11 to 14 for a comprehensive listing of options.



Self Contained CW Systems

PM / PMT

- Quasi-collimating optics
- Complete single encapsulated unit
- Constant optical output power
- Small, compact and rugged
- Wide range of wavelengths and power options

The PM laser diode modules are the simplest diode laser modules, requiring only low voltage and current for operation. They are extremely useful for those applications requiring a low noise source, highly stable beam power, stable beam pointing, a visible or infrared laser beam and low power consumption.

Adjusting Power

The PM module provides CW laser output at a constant power (CP) set during manufacture. An optional potentiometer may be added to allow subsequent adjustment of the laser power (option X-22). A modulation option (PMT) is detailed further on page 12.

If adjustable power output, drive current or reduced size is required, the SPM module detailed opposite may be more suitable. Alternatively, please refer to the modules detailed on the following pages for temperature controlled or circularised output options.

PM Module Beam Profile

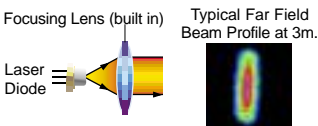

OEM CW Systems

RS / LHP / LHW

- Low cost module for OEM only
- Factory focused
- Miniature package

RS, LHW & LHP models are available for cost sensitive applications where lower performance can be tolerated. Whilst they are compatible with the majority of the diodes listed on page 12, the most economical power and wavelength options available are listed below.

RS - OEM units

The RS module is a self-contained laser diode module incorporating laser diode, collimation lens and drive circuit. This is designed solely as a low cost product for mass incorporation into other stand alone systems. The focus is factory set at 3m. The power output is fixed and an emission-warning, indicator LED, illuminates when the module is powered.

LHW & LHP - OEM head assemblies

For those customers wishing to use their own drive circuit, the LHP and LHW modules provide the most suitable and economic option. These modules are equipped with single element aspheric glass collimating lenses, which are adjustable using the standard 60tpi thread and focus key. The LHW has wires to connect to the laser diode and the LHP has the standard laser diode pin-out configuration. The wires are 300mm long nominally and the pins range from 3-13mm typically, depending on the diode.

RS	Product Code		Wavelength (nm)	Power (mW)
	LHW	LHP		
RS635-3	LHW-635-3	LHP-635-3	635	3*
RS635-5	LHW-635-5	LHP-635-5	635	5
RS670-5	LHW-670-5	LHP-670-5	670	5*
-	LHW-670-10	LHP-670-10	670	10
RS-780-5	-	-	780	5

*May be limited to Class II upon request at time of ordering.

Specifications		PM	PMT	SPM	SPMT	RS	LHW	LHP
Wavelength	nm	Choose diode from page 2 (635 to 1550nm)				For powers and wavelengths see orange table above		
Max Power Outputs	mW	Choose diode from page 2						
Constant Power / Current	CP/CC	cp / cc*4	cc	See SPM drive electronic right		cp	cp	cp
Beam Diameter (FWHM)*5	mm	4 x 1	4 x 1	4 x 1	4 x 1	4 x 1	4 x 1	4 x 1
Divergence*5	mrad	0.2 / 1	0.2 / 1	0.2 / 1	0.2 / 1	0.2 / 1	0.2 / 1	0.2 / 1
Modulation	Yes/No	No	Yes, 20MHz	No	Yes, 20MHz	No	NA	NA
Beam Pointing Stability	mrad/°C	1	1	1	1	1	1	1
Beam Circularisation	Yes/No	No*1	No*1	No*1	No*1	No	No	No
Thermoelectric Control	Yes/No	No	No	No	No	No	No	No
Input Voltage	V	2.8 - 9 (5)*2	5	See SPM drive electronic right		2.7 - 9	Diode Dependent	
Max Input Current	mA	120	300	See SPM drive electronic right		65	Diode Dependent	
Head Dimensions Ø x l	mm	13 x 51	25 x 52	13 x 17	13 x 32	11 x 37	13 x 17	13 x 14
Focusable	Yes/No	Yes	Yes	Yes	Yes	Yes	Yes	Yes
Fibre Connector Option	SM/MM	MM Only*3	MM Only*3	MM Only*3	MM Only*3	None	None	MM Only
AC Power Supply Unit		← LAS-99-423 or LAS-99-424 (see page 11) →					LDC100/200	

*1 Yes, if diode has micro-optics (see page 3 & page 6). *2 For P-type diodes (LDA - PDC) - see laser diode list *3 Please confirm with Laser 2000

*4 Can be factory set. *5 Dependent on lens (standard G3) and diode.



PMA Module



SPM Module & LDP201 Driver

Analogue Modulated, 20MHz Module

PMA

- 20MHz analogue modulation
- 200mA maximum bias current
- 100mA maximum modulation current
- Wavelengths available from 635nm to 1550nm

Laser 2000's PMA is a rugged, high-quality diode laser module that emulates an analog input signal by varying its optical output power. The PMA supports analog beam modulation from CW to 20MHz with bias currents from 0 to 200mA and modulation currents from 0 to 100mA. A benefit of analogue modulation is that it allows users to adjust a laser's output to a desired level from 0 to 100%, providing added versatility and control.

The PMA offers a variety of wavelength choices ranging from 635nm to 1550nm. (See page 2). The module is fully self-contained with drive and control electronics, laser diode, and a high-quality aspheric lens that yields a collimated beam. A 6-pin connector allows for DVM compatible monitoring of the module's parameters.

In addition, the compact PMA - which measures only one inch in diameter and approximately three inches in length - promotes easy integration into your existing or emerging application. In fact, the PMA is the perfect solution for any number of applications, including fluorescence, testing, and medical and biomedical procedures.

Contact Laser 2000.

Separated Geometry Systems

SPM / SPMT

- As PM but with additional drive electronics features

For those applications requiring more control over the laser current/power output or for those requiring a more compact laser head than the PM module, the SPM module provides a number of additional features.

The laser head is smaller than that of the PM and can be fitted into much smaller locations. This is achieved by separating the power circuit from the laser diode and optics. As the laser power supply is separate from the laser head, the heating of the laser diode by the power circuit is removed and the laser head is less susceptible to drift in beam direction and wavelength.

There are four choices of drive electronic components for the SPM series (detailed right). The appropriate choice will depend upon your design requirements. The choice of laser diode can also determine the choice of drive electronics.

Adjusting Power

The laser current and/or power output, can be set via the 3/4 turn potentiometer controls on the separate drive circuit. The set values can be read using a DVM (see LAS-99-426 on page 7).

standard laser diode modules - wavelengths from 635 to 1550nm

Module Options & Accessories - Page 11



SPM CW Drive Electronics



SPM Module & LDP214 Driver

Drive electronics for the SPM modules come in three options depending on the operating current, size or features required. All the systems operate in Constant Optical Output Power (CP) mode and the larger 201 and 251 can also operate in Constant Drive Current mode (CC).

All models feature a built-in 3/4 turn potentiometer to enable the laser power (or the drive current if operating in that mode) to be adjusted from zero to the maximum setting of the system. There are DVM compatible test points on the 201 and 251 to allow the monitoring of the laser drive current or the photodiode feedback current during operation.

LDP214 (LDP234 for LDA to PDC type (P type) diodes)

The LDP214 and LDP234 drive electronic components are small and compact. The units operate in Constant Optical Output Power mode only, where the drive system adjusts to environmental changes to maintain a constant output power from the laser. Alternatively, these power supplies may be operated in constant current (CC) mode. These units operate at the output power value set at the factory. For adjustable output power order the option X15.

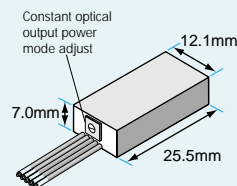

The LDP234 is designed for LDA to PDC type (P type) diodes (see laser diode chart on page 2 for P type diodes) and has a narrower operating voltage range than the LDP214 power unit.

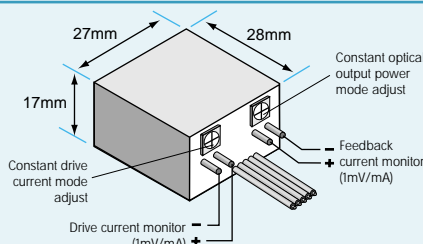

LDP201

The unit has larger filtering components than the 214 and can be used whenever possible for models that do not require the 251.

(See max current limit.)

LDP251

The 251 drive electronic component is designed for high power laser diodes. The unit includes heatsinking, with mounting bracket, along with larger filtering components for added heat dissipation.

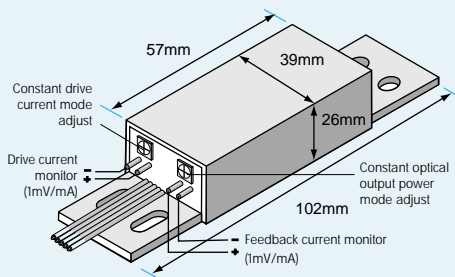

Laser 2000 will advise on which drive electronics are most suited to a particular application.

Specifications	PMA	
Modulation Trigger Signal Type		Analogue
Modulation Frequency Range	MHz	CW-20
Maximum Modulation Range	MHz@-3dB	25
Dimensions (ØxL)	mm	25.4 x 67.3
Maximum Bias Current	mA	200
Maximum Modulation Current	mA	100
Available Wavelengths	nm	635 - 1600
Operating Voltage	V	5 ± 0.5
Control Signal	V	0 - 1.0
Control Voltage Connector Type		SMC

SPM Power Supply	SPM LDP214	SPM LDP234	SPM LDP201	SPM LDP251	SPM LDP252
Operating mode	CP/CC	CP only	CP or CC	CP or CC	CP or CC
Operating Voltage	VDC	2.8 - 9.0	4.5 - 5.5	4.0 - 12.0	3.3 - 9.0
Operating Current (max.)	mA	120	120	150	1000
Case Material	Polymer Encapsulated				
Mounting	None	None	None	Al bracket	Al bracket



The laser diode modules detailed here offer a number of advanced features over those on the previous pages. These modules provide circularised beams (for applications where spot size or shape is critical), a built-in temperature controller (for those applications where wavelength or power stability is critical), or both.

The majority of the following modules are compatible with the laser diodes detailed on page 3. As the final power output of the module is dependent on the diode and the optics of the module itself, the laser diode should be selected with a greater output power than that required as there will be losses in the optical system. Refer to the notes on power output on page 3 for guidelines on the final power output of the module. Alternatively, contact Laser 2000 and we will guarantee the minimum power output level that you require.

Micro Optic Circularised Laser Diodes

Laser Diode Code #	Typ. Centre Wavelength (nm)	Output Power (mW)
LD1212	635	5
LD1251	635	10
LD1338	635	15
LD1415	639	35
LD1350	650	7
LD1240	658	35
LD1360	664	50
LD1249	670	5
LD1248	670	10
LD1438	685	60
LD1340	690	35
LD1356	785	50
LD1362	830	150

Micro Optics vs Bulk Optic Performance Comparison		Micro-optics	Bulk optic ACM
Beam Diameter	mm	1.5	3.3
Divergence (FWHM)	mrad	0.7	0.8
M ²		1.3	1.4
Power Efficiency	%	80	50
Astigmatism	waves	0.03	0.17
Coma	waves	0.05	0.36
Spherical Aberration	waves	0.04	0.38
Strehl Ratio		0.95	0.9

*Values will vary between diodes

Module Options & Accessories - Page 11



PM Module with micro optic diode



ACM Module

Micro Optic Circularised Module

- Micro-optic beam circularisation
- For use with PM, SPM & PPM
- Only available on certain diodes

These laser modules use laser diodes that have been fitted with high numerical aperture glass micro-optics. The advantages of using this method are that the output power losses are reduced compared to that of the ACM systems and that the circularisation delivers a much more uniformly circular beam with less aberration. Furthermore, the system can be focused using the standard module optics. These micro-optics lasers can be fitted into any of the standard laser modules (PM / SPM / RS / PPM) and can be collimated or focused using the internal glass optics in the module.

Only those diodes detailed in the table (shown left) are fitted with micro-optics. A comparison in the performance of a 10mW, 670nm micro-optic device and a similar diode in an ACM module can be seen in the table left.

Diodes with micro-optics may be fitted to module types PM, SPM, RS, PPM and modulatable versions.

Micro Optic Diode

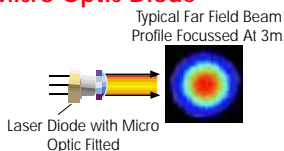

Options

All the laser diode modules on this page may be supplied with a fibre coupled output or with a range of other options. Please refer to page 11f for a comprehensive listing of options.

Bulk Optic Circularised Module

ACM / ACMT

- Standard beam circularisation
- Pseudo-circular beam
- Low astigmatism
- Collimated

The bulk optic circularised laser diode modules offer lower performance than the micro-optics circularised products (detailed left). The main advantage of this method of circularisation is that practically any laser diode may be circularised, and it is not limited to the narrow range of wavelengths and powers available in the micro-optics range. The ACM runs in constant optical power mode (CP) which is adjustable only if the option X-22 is selected when ordering. The ACM module has a fixed focus which is not adjustable. This is factory preset to give a collimated output. Alternatively, modules can be provided to your specific requirements if requested.

The laser beam is circularised using a pair of anamorphic prisms. These stretch the laser beam in one plane whilst keeping it constant in the other hence 'circularising' the beam. The remaining astigmatism is then corrected using a cylindrical lens (see below). This is an efficient and low cost method of reducing ellipticity and astigmatism.

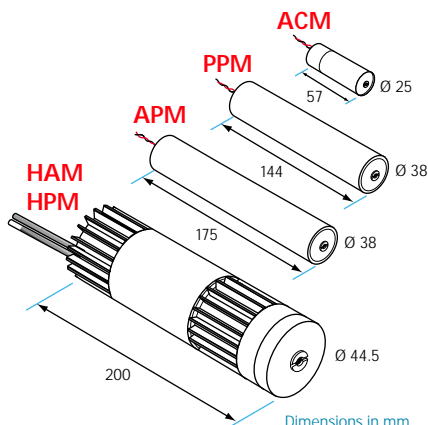
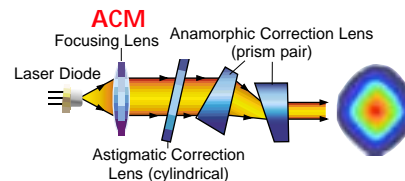

Specifications		ACM	ACMT
Wavelength	nm	Choose Laser Diode from page 2 (635 to 1550nm available)	
Max Power Outputs	mW	Choose Laser Diode from page 2	
Constant Power / Current	CP/CC	CP	CC
Beam Diameter	mm	3	3
Divergence (FWHM)	mrad	typ. <0.4	typ. <0.4
Modulation	Yes/No	No	Yes, 20MHz
Beam Pointing Stability	mrad/°C	1	1
Beam Circularisation	Yes/No	Yes	Yes
Thermoelectric Control	Yes/No	No	No
Input Voltage	V DC	2.8	5
Max Input Current	mA	200	300
Head Dimensions Ø x l	mm ²	25 x 57	25 x 57
Focusable	Yes/No	No**	No
Fibre Connector Option	SM/MM	Not available	Not available
Optional PSU		LAS-99-423 or LAS-99-424 (see page 11)	

**Please specify beam diameter required



PPM Module



APM Module



HAM Module

Temperature Controlled Module

PPM / PPMT

- **Thermoelectric control for ultimate temperature stability**
- **Focusable**
- **Built in adjustment control panel**
- **Micro-optic diodes compatible**

The PPM system incorporates a thermoelectric temperature control and fan for operation in adverse environments or for greater control over the laser power, wavelength, beam, amplitude noise or modal structure.

The temperature is controlled by means of a bipolar Peltier element to heat or cool the laser to a temperature set by the end user. The laser case temperature can be adjusted by up to $\pm 15^{\circ}\text{C}$ from ambient with a resolution of approx. 0.1°C and $<0.5^{\circ}\text{C}$ stability of the laser diode temperature. This is equivalent to a stability of the laser wavelength of approximately ± 0.1 to 0.2nm (diode dependent) once the steady state is reached (typ $<<300\text{sec}$). The upper and lower temperature limits can also be set. If the operating temperature of the laser falls outside these limits, power to the laser is stopped immediately.

The PPM laser is equipped with an adjustable focus so that it may be focused or collimated using the free focusing key provided.

PPM & APM Cooling Schematic

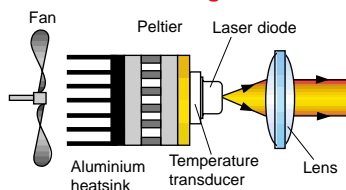

Circularised and Temperature Controlled Module

APM / APMT

- **Thermoelectric control for ultimate temperature stability**
- **Pseudo-circular beam**
- **Low astigmatism**
- **Built-in adjustment control panel**

The APM system combines the beam circularisation of the ACM (far left) with the temperature control of the PPM (left).

The APM laser diode module offers the optical performance of the ACM with the added advantage of full temperature control. The APM module has a fixed focus which is not adjustable. This is factory preset to give a collimated output. Alternatively, modules can be provided focused if requested.

High Power Module

HAM / HPM / HSM

- **Drive electronics for TE cooler**
- **Quasi collimating optics**
- **Complete sealed unit**
- **Modulated systems available**

These laser diode systems are designed for the family of high power laser diodes that have a typical operating current greater than 200mA. For effective thermal management, the system incorporates an internal fan and heatsinking. Depending on the type of laser diode selected, they will operate in either constant current or in constant optical output power mode. The HPM incorporates drive electronics for those laser diodes with a built-in thermoelectric cooler. (Please refer to diode options on page 2).

These systems are fully self-contained with power supply, laser diode, and collimating optics. The output power and wavelength of the system are dependent upon the model chosen.

Designed for the OEM, these are ideal for high power laser applications such as illumination, imaging, printing, and medical systems.

PPM & APM Power & Temperature

On the PPM & APM modules, the laser drive current, power output, laser temperature and temperature window can be set via the potentiometer control panel on the side of the module. Additionally, the actual values of the drive current, temperature window,

actual temperature and photodiode current may be read off a 7 pin connector. In all cases a voltage is output by the module which can be read using a DVM and a conversion chart (supplied with the module). Laser 2000 recommends DVM product code LAS-99-426 which is guaranteed compatible for use with all of its laser diode modules. The instrument is designed to meet IEC1010-1 category III (600V). It is suitable for industrial use and is constructed to provide long and trouble free service. It is supplied with holster, test leads, manual and batteries.



LAS - 99 - 426

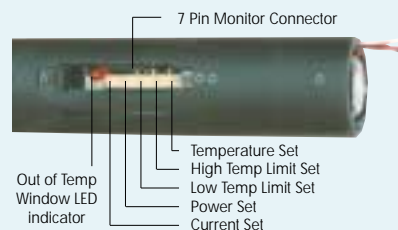

Specifications		PPM	PPMT	APM	APMT	HAM	HPM	HSM
Wavelength	nm	Choose Laser Diode from page 2 (635 to 1550nm available)						
Max Power Outputs	mW	Choose Laser Diode from page 2						
Constant Power / Current	CP/CC	CP/CC	CC	CP/CC	CC	CP or CC	CP or CC	CP or CC
Beam Diameter	mm	4 x 1	4 x 1	3	3	4 x 1 typ.	4 x 1 typ.	4 x 1 typ.
Divergence (FWHM)	mrad	0.5	0.5	0.5	0.5	Dependent on Diode		
Beam Pointing Stability	mrad/°C	1	1	1	1	-	-	-
Beam Circularisation	Yes/No	No**	No**	Yes	Yes	No	No	No
Thermoelectric Control	Yes/No	Yes	Yes	Yes	Yes	No	Yes	Yes
Input Voltage	V DC	12	12	12	12	12	12	12
Max Laser Diode Drive Current	mA	350***	200	350***	200	2000	1000	2000
Max Input Current	mA	1200	1350	1200	1350	2400	3200	4200
Head Dimensions $\varnothing \times l$	mm ²	38 x 144	38 x 144	38 x 175	38 x 175	45 x 200	45 x 200	45 x 250
Focusable	Yes/No	Yes	Yes	No	No	Yes	Yes	Yes
Fibre Connector Option	SM/MM	SM/MM	SM/MM	Not available	Not available	MM**	MM**	MM**
Optional PSU		← LAS-99-423 or LAS-99-424 (see page 11) →						

** Depends on diode (please confirm with Laser 2000 UK) *** Separate driver



PPM Module

100mW @ 410nm, 20mW @ 440nm, 10mW @ 375nm
plus new 470nm!

Blue, Violet, & Ultraviolet Module

- *Very stable wavelength*
- *Adjustable focus*
- *Quality glass optics*
- *Standard beam centring*
- *Single transverse mode*
- *Optional beam expanding optics*

Compact, versatile, and highly cost-effective, Laser 2000's blue, violet, and ultraviolet laser modules are ideal replacements for bulky, inefficient gas lasers. Most applications that use Argon-Ion, Helium Cadmium, and tripled Nd:YAG lasers can take advantage of this newer, more efficient technology. Applications that can benefit from this technology include fluorescence, spectroscopy, high-resolution printing, microscopy, cytometry, display, and medical diagnostic procedures.

To meet the demands of your application, Laser 2000 now offers a 5mW @ 440nm blue, 5mW and 30mW @ 405nm violet diodes, and a 2mW @ 385nm ultraviolet laser. Each of these modules has an exceptional temperature coefficient of only 0.06nm/°C, whereas an average red or infrared laser diode has a temperature coefficient of 0.3nm/°C. In addition, the modules' integrated thermoelectric coolers keep the laser diodes operating at 20°C, prolonging the life of the diodes and further promoting wavelength stability.

Each module measures 38mm x144mm and requires 12VDC at 1.35A maximum. Beam centring is standard.

The diode may operate in constant current mode.

Since blue laser diodes are smaller and more competitively priced than some other blue laser sources, they make applications practical with smaller size and competitiveness. Some applications include fluorescence, spectroscopy, medical, display, high-resolution printing, interferometry, and microscopy.

An additional model featuring TTL modulation from 0-20MHz is also available. This feature can also be used to activate and deactivate the laser in a quasi-CW mode (see T option, page 12).

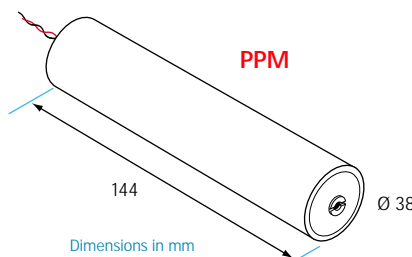
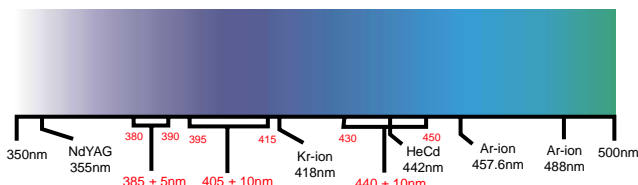

Dimensions in mm



Blue

The temperature controlled PPM04(LD1406) emits a >3mW beam of blue light at 440 ± 10nm. With an estimated mean time to failure in excess of 10,000 hours, the 440nm blue laser module serves as reliable component for a variety of applications, including fluorescence, microscopy, and interferometry.

Violet

The PPM25(LD1432) and PPM04(LD1382) are temperature controlled laser diode modules that emit violet light at 405 ± 10nm. The powerful PPM25(LD1432) emits >25mW of output power and offers an estimated mean time to failure of 10,000 hours. The economical PPM04(LD1382) emits >3mW of output with an extremely high estimated mean time to failure of 15,000 hours.

Violet lasers provide a versatile solution to any number of OEM applications, from fluorescence to spectroscopy to high-resolution printing. Call today to take advantage of this innovative technology.

Ultraviolet

Laser 2000's temperature controlled PPM04(LD1435) yields a >1mW beam of ultraviolet light at 370 ± 10nm. This unique module offers an estimated mean time to failure in excess of 2000 hours. Ideal for a vast array of medical and biomedical applications, the 370nm PPM module provides exceptional quality in a compact package.

In addition, circular versions of members of the blue, violet, and ultraviolet family are available to provide even more power density and efficiency. Typical diode lasers produce a low-quality beam that is highly divergent, elliptical, and astigmatic. Our advanced circularising technology corrects for these deficiencies and yields a strong, high-quality beam.

Temperature Controlled Blue, Violet and UV Module Specifications

Specifications	PPM04 (LD1406)	PPM04 (LD1382)	PPM25 (LD1432)	PPM04 (LD1435)
Wavelength (nm)	440 ± 10	405 ± 10	405 ± 10	370 ± 10
Output Power (diode) (mW)	5	5	30	2
Estimated Lifetime (hours)	>10,000	>15,000	>10,000	>2000
Operating Temperature (°C)	+10 - +40	+10 - +40	+10 - +40	+10 - +40
Max. Heating/Cooling (°C)	-20/+10	-20/+10	-20/+10	-20/+10
Operating Voltage (VDC)	12	12	12	12
Max. Operating Current (mA)	1350	1350	1350	1350
Typical Operating Current (@25°C, mA)	400	400	400	400
Astigmatism (µm)	-	<4	-	-
Beam Divergence (G3A lens, mrad)	0.2 x 0.4	0.2 x 0.4	0.2 x 0.4	0.2 x 0.4
Collimated Beam Size at Exit (G3A lens, mm)	5.7 x 2.2	5.7 x 2.2	5.7 x 2.2	5.7 x 2.2
Finish Anodised Colour	black	black	black	black



IQ Series Laser Modules

IQ1 / IQ2

- CW, analog modulation, or digital beam modulation
- PID temperature controller
- Precision current source
- Circular or elliptical beam
- Quality glass optics
- Wavelengths from 370 to 1600nm

Our IQ laser heads and modules are "instrument quality" OEM products with superior thermal and optical specifications. They are excellent choices for any number of analytical applications requiring stability of wavelength and output power. For applications that can benefit from the merged output of two IQ heads, we also offer a dual beam combiner.

IQ Series Laser Modules

For high-end OEM applications requiring superior optical quality and ultra-stable temperatures, wavelengths, and output powers, our IQ series laser modules are the perfect solution. IQ modules feature a precision current source and a PID temperature controller. They incorporate quality glass lenses and can host laser diodes with wavelengths from 370 to 1600nm. IQ modules can operate in either constant current or automatic power control mode.

In addition, our IQ series lasers are available with CW, analog modulated, or TTL modulated output. The IQ1C model operates in CW mode and can deliver up to 1000mA of drive current. The IQ1H version is capable of 100MHz digital beam modulation, while the IQ1A can deliver 20MHz of analog beam modulation. Each is available with a standard elliptical beam or a circular beam achieved via a microlensed diode. Also available are the IQ2C, IQ2H, and IQ2A, alternate models that feature anamorphic correcting prisms to produce a circularised beam.

IQ modules are excellent choices for a variety of analytical applications, including fluorescence, spectroscopy, interferometry, high-resolution printing, display, and microscopy.



Instrument Quality Laser Head

IQ Head

IQH

- Integrated TE cooler
- Superior heat dissipation
- Small form factor
- Quality glass optics
- Precision centring
- Small beam size
- Good pointing stability

The IQ laser head is an Instrument Quality (IQ) OEM laser head with superior thermal, mechanical, and optical specifications.

The IQ laser head features a custom-made TE Cooler capable of moving 7.1 Watts of heat from the hot side to the cold side of the cooler. Unlike other laser modules that pull heat from one side of the laser diode, the heat in the IQ is removed symmetrically from the diodes largest heat bearing surface - the bottom. A10kΩ thermistor is provided to monitor the laser temperature.

At the heart of the IQ laser head is a proprietary design that provides maximum heat transfer from the laser diode to the IQ's base, a high degree of centring accuracy, and very good beam pointing stability. The head's centring feature actually aligns the diode to the mechanical centre of the brass mounting base while negating the angular displacement found in all laser diodes. This produces a truly centred laser beam. The alignment can be easily adjusted by the customer to suit their particular needs. Since most laser diodes have a chip mounting tolerance of ±50µm and an angular mounting tolerance of ±3°, this feature becomes critical in producing a really high quality laser module.

The IQ laser head should only be mounted around the brass-mounting base. This provides maximum beam pointing stability and the best thermal transfer to the customer supplied heat sink or to Laser 2000's accessory heat sink.

An IQ temperature controller with a PID control loop and a IQ laser diode driver are available to complete any instrument. (See page 5).

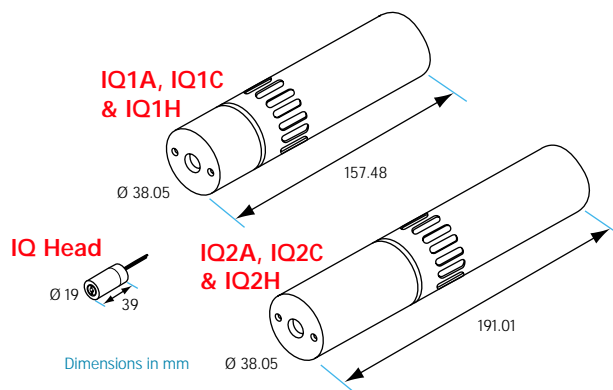

Specifications		IQ1A/IQ2A	IQ1C/IQ2C	IQ1H/IQ2H	IQH
Dimensions, Ø x L,	mm	38.05 x 157.48 / 38.05 x 191.01	38.05 x 157.48 / 38.05 x 191.01	38.05 x 157.48 / 38.05 x 191.01	19.05 x 38.35
Operating Voltage	VDC	11 - 14	11 - 14	11 - 14	diode dependent
Max. Operating Current	mA	3000	3000	3000	-
Max. Laser Drive Current	mA	-	1000	-	-
Mod. Frequency Range	MHz	CW - 20**	-	CW - 100**	-
Mod. Current Above Bias	mA	1000 bias + 200 mod.	-	1000 bias + 120 mod.	diode dependent
Temperature Stability	°C	.002	.002	.002	controller dependent
Temperature Range	°C	0 - 40	0 - 40	0 - 40	controller dependent
Physical Diode Compatibility		9mm, 5.6mm	9mm, 5.6mm	9mm, 5.6mm	9mm, 5.6mm
Diode Compatibility		all	all	all	driver dependent

**Maximum modulation frequency may vary depending on the laser diode chosen.



ML Series Pulsed Laser Modules

ML Series

- Offer high peak output powers of up to 100W
- Require only a DC input voltage & TTL timing trigger to operate
- Offer a variety of wavelengths to meet your pulsed laser diode needs

Our ML, ILC, and IPC pulsed laser modules feature peak output powers of up to 100W. In addition, they offer pulse widths ranging from 7 to 50ns with fast rise and fall times. The compact design of these modules provides users with the flexibility to incorporate them into a variety of OEM products.

The ML family of pulsed laser modules offers peak output powers of up to 100W at 905nm. These units include the laser diode, focusing lens, and pulse drive electronics and require only a regulated DC input voltage and a TTL timing trigger to operate. ML series pulsers are ideal for applications requiring high peak pulse powers, such as rangefinding and LIDAR.

ILC & IPC Series Pulsed Laser Modules & Controllers

ILC & IPC Series

- ILC pulsers contain an internal power supply that allows for either a built-in trigger pulse or a user-supplied trigger
- IPC pulsers do not incorporate an internal power supply

Our ILC and IPC pulsers offer peak pulse currents from 1 to 105A and pulse widths from 7 to 500ns. Available wavelengths include 850, 905, 1064, and 1550nm. Pulsers in the ILC family contain an internal power supply that allows for either a built-in trigger pulse or a user-supplied trigger. IPC pulsers do not incorporate an internal power supply, so users must supply a trigger pulse and a bias voltage. Both series are temperature compensated to regulate output power, and both are suitable for any number of applications, including rangefinding, freespace communications, LIDAR, and biomedical analysis.

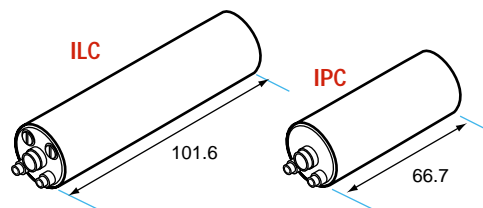
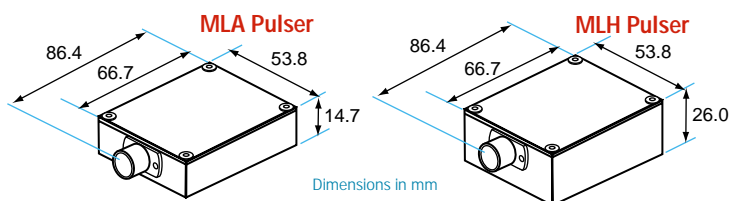

Module Specifications		ML20A15	ML40H15	ML60H15	ML100H15
Dimensions, W x L x H	mm	53.85 x 86.44 x 14.73	53.85 x 86.44 x 26.01	53.85 x 86.44 x 26.01	53.85 x 86.44 x 26.01
Peak Output Power	W	20	40	60	100
Pulse Width	ns	15	15	15	15
Max. Pulse Repetition Frequency	kHz	10	10	6	5
Operating Voltage	VDC	9 - 14.5	9 - 14.5	9 - 14.5	9 - 14.5
Max. Operating Current	mA	100	150	120	150
Max. Laser Drive Current	mA	17000	17000	20000	21000

Pulsers Specifications		IL9C	IL10C	IL20C	IL25C	IL30C	IL40C	IL60C	IL75C
Dimensions, Ø x L	mm	25.4 x 101.6	25.4 x 101.6	25.4 x 101.6	25.4 x 101.6	25.4 x 101.6	31.75 x 101.6	31.75 x 101.6	31.75 x 101.6
Pulse Current (adjustable)	A	1 - 9	6 - 11	11 - 22	14 - 27.5	16 - 33	22 - 44	33 - 66	41 - 82.5
7-50ns	Rise Time (typical)	ns	2	3	4	4	5	5	8
Pulse Width	Fall Time (typical)	ns	2	3	5	6	7	8	10
	Rise Time (typical)	ns	12	14	16	18	20	22	24
51-200ns	Fall Time (typical)	ns	14	16	18	20	22	26	28
	Maximum External Trigger	kpps	50	40	30	20	20	20	15
Pulse Rate	Internal Clock	kpps	20	20	20	20	20	20	20
Propagation Delay	ns	10	10	10	10	10	10	10	10
Supply Voltage	VDC	12 - 24	12 - 24	12 - 24	12 - 24	12 - 24	12 - 24	12 - 24	12 - 24
Physical Diode Compatibility		9 & 5.6mm	9 & 5.6mm	9 & 5.6mm	9 & 5.6mm	9 & 5.6mm	9 & 5.6mm	9 & 5.6mm	9 & 5.6mm
		8:32, 10:32	8:32, 10:32	8:32, 10:32	8:32, 10:32	8:32, 10:32	8:32, 10:32	8:32, 10:32	8:32, 10:32

Pulsers Specifications		IP9C	IP10C	IP20C	IP25C	IP30C	IP40C	IP60C	IP75C	IP100C
Dimensions, Ø x L	mm	25.4 x 66.68	25.4 x 66.68	25.4 x 66.68	25.4 x 66.68	25.4 x 66.68	31.75 x 66.68	31.75 x 66.68	31.75 x 66.68	31.75 x 66.68
Pulse Current (adjustable)	A	1 - 9	6 - 11	11 - 22	14 - 27.5	16 - 33	22 - 44	33 - 66	41 - 82.5	55 - 105
7-50ns	Rise Time (typical)	ns	2	3	4	4	5	5	8	10
Pulse Width	Fall Time (typical)	ns	2	3	5	6	7	8	10	12
	Rise Time (typical)	ns	12	14	16	18	20	22	24	26
51-200ns	Fall Time (typical)	ns	14	16	18	20	22	26	28	30
	Max. Pulse Rate	kpps	100-1000	100	100	100	100	75	50	40
Propagation Delay	ns	10	10	10	10	10	10	10	10	10
Physical Diode Compatibility		9 & 5.6mm	9 & 5.6mm	9 & 5.6mm	9 & 5.6mm	9 & 5.6mm	9 & 5.6mm	9 & 5.6mm	9 & 5.6mm	9 & 5.6mm
		8:32, 10:32	8:32, 10:32	8:32, 10:32	8:32, 10:32	8:32, 10:32	8:32, 10:32	8:32, 10:32	8:32, 10:32	8:32, 10:32



Laser 2000 provides a range of options to its standard laser diode modules. These options greatly enhance the capability of the individual modules providing a wide range of additional features. The following options are generally compatible with the range of laser diode modules detailed in this catalogue. Please note that some module options may not be used with some laser diode modules. For full advice on compatibility issues, please contact Laser 2000.



LAS-99-423

Benchtop Power Supplies

LAS-99-423

The LAS-99-423 is the recommended benchtop power supply for driving the APM, PPM, HAM, and HPM laser diode modules. Furthermore, it is also the recommended supply for the LDP 251 separate geometry laser diode drive circuit. The unit is capable of delivering up to 3A at 30V. It may be operated in current adjustment or voltage adjustment mode and it provides clear and precise read-outs of both parameters simultaneously via two front panel analogue gauges. The LAS-99-423 is also the recommended power supply unit for the diode pumped solid state lasers of the LCM series. The LAS-99-423 is provided with an IEC mains connector. Front panel screw connectors are provided for attachment of all laser module flying leads.

NB. This power supply is not suitable for use with bare or unprotected laser diodes. Refer to our "Laser Diodes" PDF for suitable drive electronics.



LAS-99-424

Regulated Adaptor and Connection kit

LAS-99-424

The LAS-99-424 is the recommended regulated DC adaptor for driving the PM, RS, ACM, series laser diode modules, and the LDP 214, LDP234, and LDP 201 separated geometry drive circuits. The unit is capable of delivering up to 900mA at 1.5-9VDC. The output voltage may be adjusted via a selection switch accessible by screwdriver. As the output is regulated, voltage fluctuations are minimised ensuring excellent performance.

These compact units are moulded in high impact resistant plastic and the output is provided with a range of connectors. Compatible female connectors are provided with (but not attached to) the laser diode module.

NB. This power supply is not suitable for use with bare or unprotected laser diodes. Refer to our "Laser Diodes" PDF for suitable drive electronics.



TCB

Precision Temperature Controller

TCB

Overview

The TC series of temperature controllers feature a PID (Proportional-Integral-Derivative) control loop for use with thermoelectric coolers. Capable of delivering 2A at 7V, the TCB provides a full 14W of electrical power to a thermoelectric cooler.

The TCB is designed for the tightest tolerance applications that require ultra stable temperatures. Whether its laser diodes, CCDs, or detectors, the TC series can control the temperature accurately and efficiently.

Accuracy and Stability

With a one hour stability of $\pm 0.002^{\circ}\text{C}$ and a 24 hour stability of $\pm 0.004^{\circ}\text{C}$, the TCA and TCB are suitable for even the most critical measurement, analytical, and scientific applications.

Applications

CCDs – The spectral response of certain CCDs can be improved by cooling the CCD. These include cameras that see above $1.1\mu\text{m}$.

Laser Diodes – Laser diode operating characteristics can vary widely with changes in temperature. Wavelength, power stability, threshold current and lifetime are all affected with changes in temperature. Precise temperature control can also help eliminate mode hopping.

Detectors – Noise levels in most solid - state detectors, such as APDs, can be decreased by maintaining a lower operating temperature. Spectral response also varies with operating temperature.



LDCU

Laser Diode Control Unit

LDCU

The Laser Diode Control Unit (LDCU) is a turnkey power source that enables Laser 2000 (UK) Ltd. to offer original equipment manufacturer (OEM) laser products as complete laser systems.

The LDCU incorporates the following safety features: a power on/off key switch, emission indicator, 5-second activation delay, and remote interlock connector. In addition, laser systems above 4.5mW feature a beam attenuator to prevent unwanted radiation emissions, and systems above 450mW include a manual reset button on the front panel.

Laser 2000 offers several versions of the LDCU, each designed to accommodate laser modules with one of the following operating voltages: 3.3VDC, 5VDC, and 12VDC.

Input voltages of 100VAC, 120VAC, and 220VAC are available for this safe, easy-to-use power source.

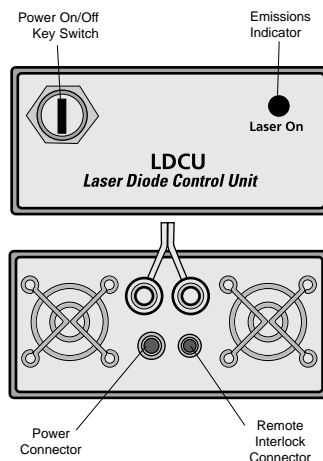
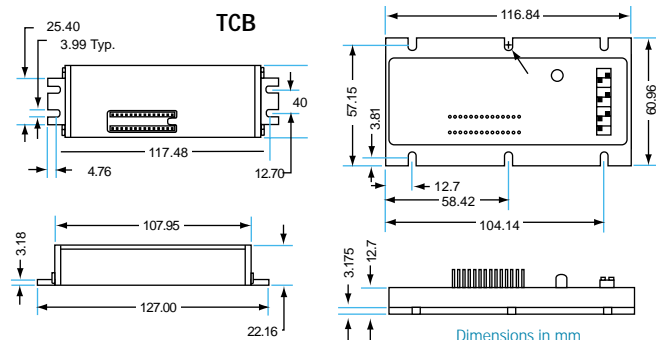
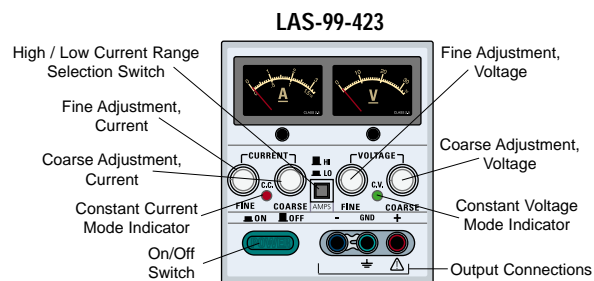

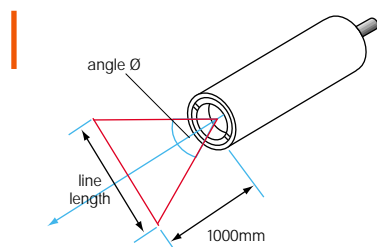

NB.-Linewidth is defined by focusing or defocusing the laser module optics.

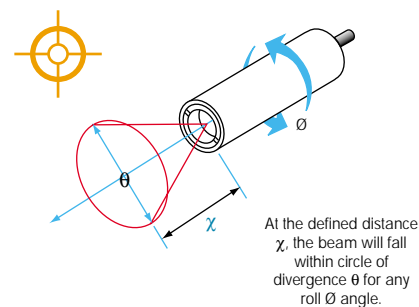

20 MHz Digital Modulation Option (Enable / Disable)

-T

The PM and SPM, PPM, ACM and APM laser diode module systems can all be modulated externally using the -T option. (On the APM and PPM systems only the MAX power level is adjustable via the potentiometer control panel.)

The T modulation option enables the user to modulate the output power of the laser diode digitally between zero and maximum power via an external 5V TTL input (user supplied). When the TTL is at +5V, laser power is OFF. When the input is at 0V DC the laser power is MAX. The maximum modulation frequency is 20MHz in any combination of mark-space ratios with an extinction ratio of 100-1 between maximum power and zero power. Essentially this option may be used as a remote "switch on or off" of the device.

Note: All the modulated systems operate in 'Constant Drive Current' mode only. These systems cannot utilise a feedback system to regulate the laser power and instead operate at a factory preset laser drive current (specified within the limits of the system). Optional potentiometer controls are available for adjustment of the Constant Drive Current (option X-22).

Function Generator

The LAS-99-425 is the recommended function generator for providing the modulation input for -T version modulatable laser diode modules at up to 2MHz. The LAS-99-425 provides a fixed frequency TTL output which may be adjusted from 0.002Hz to 2MHz using the front panel controls. It is mains powered and is supplied with an IEC cable. The interface between the modulator and laser diode module is made via BNC connector.

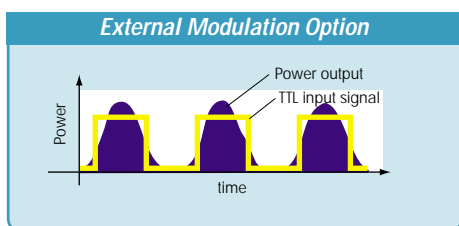

Line Generation Lenses

-Lx

All Laser 2000 laser diode modules may be fitted with a range of different line generation lenses. These lenses transform the collimated output of the laser diode into a 2 dimensional fan of light that diverges at a uniform rate projecting a line onto any surface. The line dimensions are governed by the type of line generation lens used and the distance of the laser from the target surface. The line length is a function of the full fan angle and this distance. As the line generation lens is used in combination with the standard laser diode collimating lens, the thickness of the line is generally of the order of 1mm. However the width of the line can be reduced by focussing the collimation optic so that the spot size is smallest at the point onto which the line is to be projected. Then, when the line lens is fitted over the collimation optic, the line width will be focussed to it's narrowest width at this point. Orientation of the projected line is achieved simply by rotating either the module or the line lens itself.

The line lens is a factory fit option and should be ordered at the time that the module is ordered although it is possible to retrofit this option at a later date.

Beam Centering

-C

The laser diode is centred in the laser module so that the output beam is aligned to the centre-line of the module. As the module is rotated, the laser diode output beam remains in the centre and there is negligible eccentric movement of the laser diode spot.

The tolerance is ± 0.5 mrads (except the ACM which is ± 2.5 mrads). Note that this is defined only at a fixed distance from the module.



Power Supplies - Page 11

Line Generation Lenses

LENS Part #	Lens Type	Approximate Line "Length @ 12" ""	Full Fan Angle
L0	PCX Rectangular	15mm	2.8°
L9	PCX Rectangular	21mm	4.0°
L8	PCX Rectangular	29mm	5.5°
L7	PCX Rectangular	40mm	7.6°
L70	Non-Gaussian	53mm	10°
L6	PCX Rectangular	80mm	15°
L3	PCX Rectangular	96mm	18°
L13	Plastic Disk	102mm	19°
L71	Non-Gaussian	107mm	20°
L5	PCX Rectangular	124mm	23°
L4	PCX Rectangular	152mm	28°
L72	Non-Gaussian	163mm	30°
L2	PCX Rectangular	198mm	36°
L73	Non-Gaussian	252mm	45°
L74	Non-Gaussian	352mm	60°
L1	Rod	352mm	60°
L76	Semi-Gaussian	512mm	80°
L75	Non-Gaussian	610mm	90°
L10	Rod	610mm	90°

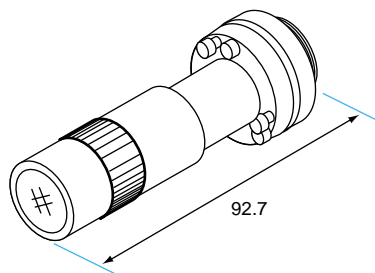
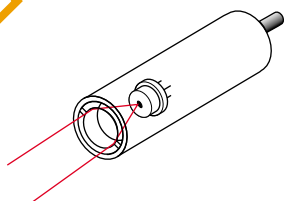

Remote Control Diode Module

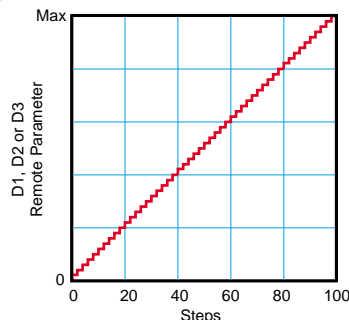

Collimating Lenses

-Gx

All laser diode modules supplied by Laser 2000 are factory fitted with a collimation lens as standard. The function of the collimation lens is to capture as much of the source beam as possible and transform this into a low divergence parallel beam (collimated output). There are a variety of collimation lenses designed either to capture the most light or to provide the lowest divergence. All modules as standard are fitted with the G3 collimation lens which provides the combination of efficiency and divergence, typically 70% throughput and around 1mrad respectively. For those applications requiring higher light throughput or lower divergence, please refer to the options detailed below.

As collimation lens are factory fitted, collimation lens options should be ordered at the same time as the laser module. It is however possible to retrofit collimation lenses. For further details, please contact Laser 2000.

Telescope Option

-Tx

- *Telescope collimators are used to reduce, enlarge, or collimate output beams*

Telescope collimators are used to reduce, enlarge, or collimate output beams. They may also be used to focus beams on small areas at long distances. We offer a wide selection of compact telescope accessories that attach to the front end of a laser module. Telescopes are available as options for the following modules: PM, APM, ACM, PPM, SPM, and all modulated versions of these lasers.

Telescope Option	
Beam Expanders (18mm Output Aperture)	
T7	4X beam expanding with threaded end for additional optics
T11	4X beam expanding/collimating telescope
T9	6X beam expanding/collimating telescope
T20	6X beam expanding with threaded end for additional optics
T17	7.5X beam expanding/collimating telescope
Simple Beam Reducers	
T19	0.17X
T13	0.25X
T16	0.33X
T25	0.40X
T6	0.50X

Remote Control

-Dx

The remote control option -Dx enables the laser diode module output power, drive current or temperature to be changed electronically. The standard option allows the chosen parameter to be varied in 100 increments between the minimum setting (or zero) and the maximum setting for the parameter in question. Additional options are available which increase the number of increments to 256 steps and 512 steps.

Laser diode modules fitted with the remote control option are provided with additional wiring to allow the enduser to connect the unit to their own control electronics. The switching electronics require an input of 5VDC to toggle the unit to the next step, either to increase or decrease the chosen parameter. At the same time, the direction of the step can be changed so that an increase can be reversed and vice versa. This is done through using another 5V supply line. In both cases, the unit uses TTL logic to toggle the change. As there is very little current draw, the power requirements for the diode module remain very low.

The response time of the remote control circuit to effect the change requested by the electronics is typically 1msec. Those end-users wishing to switch a laser output on and off at higher speeds than this should consider the external modulation option -T or the analogue modulation unit, the PMA.

Please note that options D1, D2, D4, D5, D4b, and D5b are mutually exclusive.

D1, D4 and D4b cannot be fitted to modulated modules.

Furthermore, D3, D6, D6b can only be fitted to temperature controlled modules.

Collimating Lenses

Lens Model No.	Lens Type	Clear Aperture	Diameter (mm)	N.A.	E.F.L.	Notes
G1B	ASPH - Aspheric	2mm	3.00 ±0.015	0.5	2.0mm	↑ Better Light Collection Efficiency Higher Divergence
G1C	ASPH - Aspheric	2.0mm	3.00 ±0.015	0.5	2.0mm	
G20	ASPH - Aspheric	3.3mm	4.40 ±0.01	0.55	3.00mm	
G16	ASPH - Aspheric	4.0mm	6.40 ±0.01	0.5	4.00mm	
G2B	ASPH - Aspheric	4.96mm	6.325 ±0.015	0.55	4.51mm	
G2C	ASPH - Aspheric	4.96mm	6.325 ±0.015	0.55	4.51mm	
G2M-1K	ASPH - Aspheric	4.89mm	6.00 ±0.03	0.53	4.6mm	
G7B	ASPH - Aspheric	3.7mm	4.70 ±0.015	0.3	6.16mm	
G7B-1C	ASPH - Aspheric	3.7mm	4.70 ±0.01	0.3	6.16mm	
G7C	ASPH - Aspheric	3.7mm	4.70 ±0.015	0.3	6.16mm	
G3B	ASPH - Aspheric	5mm	7.20 ±0.015	0.4	6.24mm	Fitted as Standard
G3C	ASPH - Aspheric	5mm	7.20 ±0.015	0.4	6.24mm	↓ Higher Collimation (Lower Divergence)
G3B-1	ASPH - Aspheric	5.35mm	6.40 ±0.01	0.4	6.25mm	
G10B	ASPH - Aspheric	5.46mm	6.40 ±0.01	0.39	7.00mm	
PZ	PLAS - Plastic Aspheric	4.8mm	7.00 ±0.03	0.3	8mm	
G4B	ASPH - Aspheric	8mm	9.94 ±0.015	0.5	8mm	
G4C	ASPH - Aspheric	8mm	9.94 ±0.015	0.5	8mm	
G6B	Selfoc Gradient Index Lens	3.4mm	4.47 ±0.03	0.14	12mm	

Remote Control	
D1-	Optical Output Power
D2-	Digital Control (100 Positions) Laser Drive Current
D3-	Digital Control (100 Positions) Laser Temperature
D4-	High Resolution Optical Output Power Digital Control (256 Positions)
D5-	High Resolution Laser Drive Current Digital Control (256 Positions)
D6-	High Resolution Laser Temperature Digital Control (256 Positions)
D4b-	High Resolution Optical Output Power Digital Control (512 Positions)
D5b-	High Resolution Laser Drive Current Digital Control (512 Positions)
D6b-	High Resolution Laser Temperature Digital Control (512 Positions)



PPM-F2 Module:
PPM module
(page 7) with
singlemode fibre
connection and
FC/PC connector

Optical Fibre Connectorisation

-F2 (singlemode FC/PC) / -F7 (multimode FC/PC)

The laser diode output may be coupled into a fibre optic cable. Fibre connectorisation with multimode fibre is available for all laser diode modules on pages 4 to 7. Singlemode fibre may be connectorised to the PPM module (page 7) only. Not all diodes may be connectorised.

The laser diode module is equipped with an FC/PC fibre connector to which the laser diode is aligned. This launches the laser light into the connected fibre. Fibres of different lengths or core geometries may be fitted to the module quickly and easily for maximum versatility. If a fibre becomes damaged for any reason, a repair can be made economically and with maximum convenience. Alternatively a different laser wavelength may be added into a system with minimum effort.

Adding a fibre connector reduces the diode output power. Refer to the notes on page 3 regarding power output. Most modules may be fitted with the F7 multimode fibre option, but only the PPM module may be fitted with the F2 singlemode option.

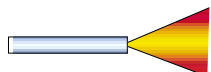

- **Bare ended (default):** terminated with an industry standard connector. (See options table, below).

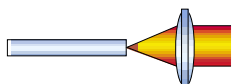

- **Terminated with a collimating unit:** Specify preferred collimated spot size, distance and tolerance. (See "Accessories" PDF).

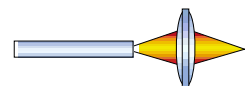

- **Terminated with a focusing unit:** Specify preferred focused spot size, working distance and tolerance. (See "Accessories" PDF).

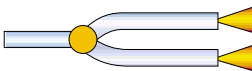

- **Connected to splitter** (See "Accessories" PDF).

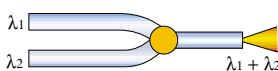

- **Connected to wavelength multiplexer** (Contact Laser 2000).

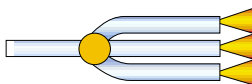

- **Connected to fibre bundle** (Contact Laser 2000).

Option	Description
F1	Multimode Fibre with SMA Connector
F2	Single Mode Fibre with FC Connector
F3	Single Mode Fibre with ST Connector
F5	Multimode Fibre with ST Connector
F7	Multimode Fibre with FC Connector

Mounting Brackets

Product Code	Module Dia (mm)
MB1	12.7mm
MB2a	12.7mm
MB2c	11mm
MB3a	12.7mm
MB3c	11mm
MB5	25.4mm
MB6	38mm



PM-ACS-MB2 with laser module

PM-ACS-MB1 with laser module

Mounting Brackets

MB Series

The Laser 2000 range of mounting brackets is designed to provide rigid mounting and adjustment for the standard range of 12.7mm, 25.4mm and 38.0mm diameter laser diode modules. In addition to the mounts detailed here, laser diode modules of larger diameters may be mounted in our standard range of HeNe mounts detailed in the "Gas Lasers" PDF.

Laser 2000 also provides a wide range of mounting systems for bare laser diodes. Please refer to the laser diodes section in this catalogue.

The MB1 is a multidirectional, single axis mounting bracket that promotes precise laser positioning. This bracket is constructed of durable black anodised aluminum. The MB1 accommodates modules 12.7mm in diameter and is ideal for use with PM lasers.

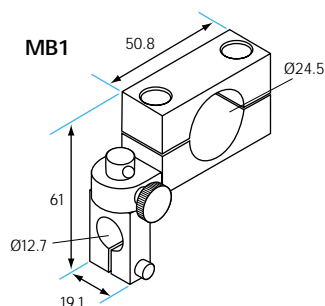

The MB2 is a fixed mounting bracket. Constructed of black anodised aluminum, the MB2 features a split ring clamp. This bracket is available in two sizes. One model - suitable for RS lasers - secures modules 11mm in diameter, while the other model - ideal for PM lasers - accommodates modules 12.7mm in diameter.

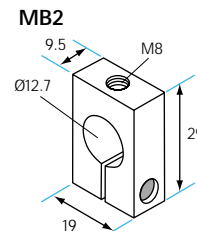

The MB3 provides the highest level of adjustment of all the mounting brackets. This versatile bracket is multidirectional and features a freely rotating brass ball. The ball allows for 80° conical rotation and is available in two sizes: 11mm and 12.7mm. Constructed of Delrin, the MB3 is suitable for PM or RS modules.

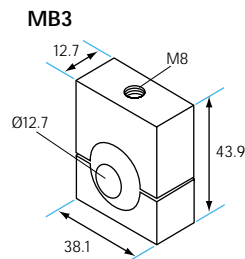

The MB5 and MB6 are fixed mounting brackets that are constructed of black anodised aluminum. Each features three M6 mounting holes on the bottom for added stability. These holes enable a module not only to be incorporated easily into an OEM application but to be attached firmly to an optical bench. The MB5 secures modules 25.4mm in diameter and is ideal for PMT, PMH, ACM, PMA, and ACMT lasers. The MB6 accommodates modules 38mm in diameter and is suitable for PPM and APM lasers, which generally require two brackets for optimum stability.

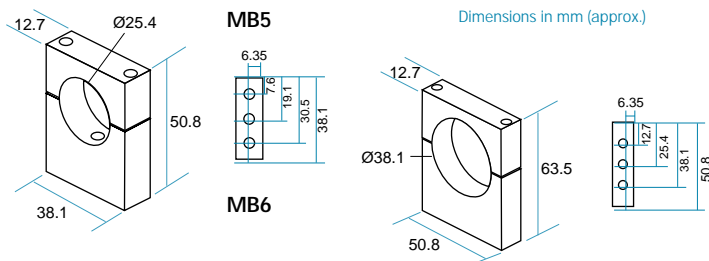

Dimensions in mm (approx.)